

For a 12-foot sailer that also takes 2-3 HP outboard motors, try—

Breeze Baby

By WILLIAM D. JACKSON

SKIMMING off a brisk wind or with the wind abeam, *Breeze-Baby* actually planes with one person aboard. Despite her rowboat lines (that make her easy to build), she handles easily under her simple sail, an ideal "first" boat. Simple lines are adapted to plywood construction that's strong, light and that keeps *Breeze-Baby's* bilges dry. You can take her with you atop your car or on a lightweight trailer for summer fun wherever you vacation or get in a week-end's sailing.

Since *Baby* is built over mold frames that are later removed when planking is complete and the seats and knees are in place, the inside is easy to scramble around in without stumbling over permanent frames. Even the form that supports *Baby's* keel and molds can be sawed up for storage skids when she's out of the water.

To get started building *Breeze-Baby*, lay out full-size patterns of the stem, transom and mold frames on red rosin paper (available at lumber yards) and a soft pencil (Figs. 1 and 3). Build up mold frames #1 and #2 from 2x4 bottom members, 1x4 side members and diagonal braces to keep frames from twisting to fit patterns.

Set the finished molds aside and cut out the paper patterns for the transom and stem with a sharp razor blade exactly to shape. You can lay these patterns over the 1 $\frac{3}{4}$ in. stock for the stem

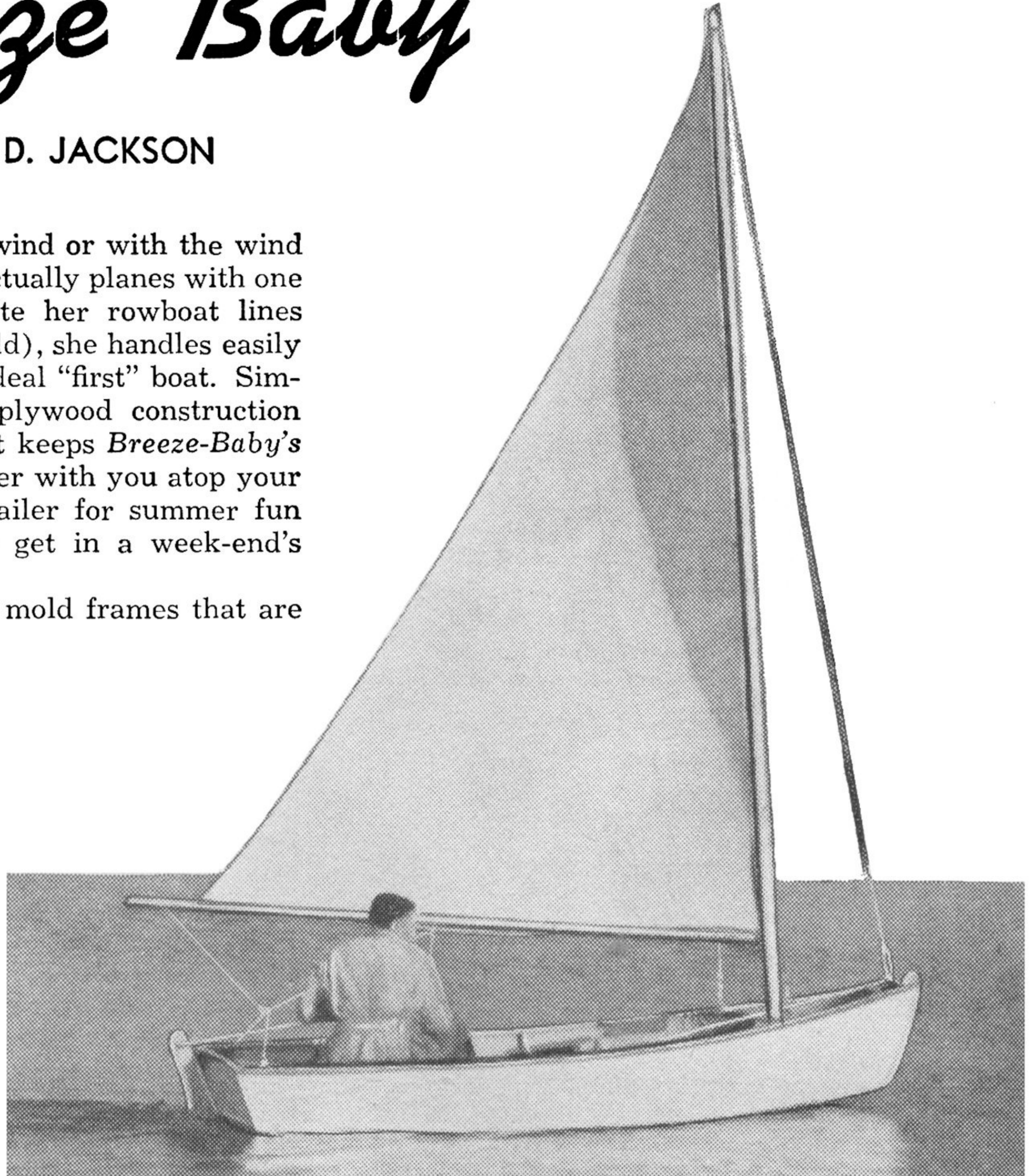

and $\frac{1}{2}$ in. plywood and $\frac{3}{4}$ in. frame pieces for the transom; saw them to shape. Glue the outline frame pieces to the transom with waterproof plastic rosin glue (*Weldwood*) and screwfasten them with #8 x 1 in. *fh* screws spaced at 3 in.

When you're buying plywood, insist on Exterior AA grade. If the plywood does not have the edge brand, *Ext. DFPA*, required by the govern-



Left, form with temporary molds in place. Right, framework completed with transom in place.

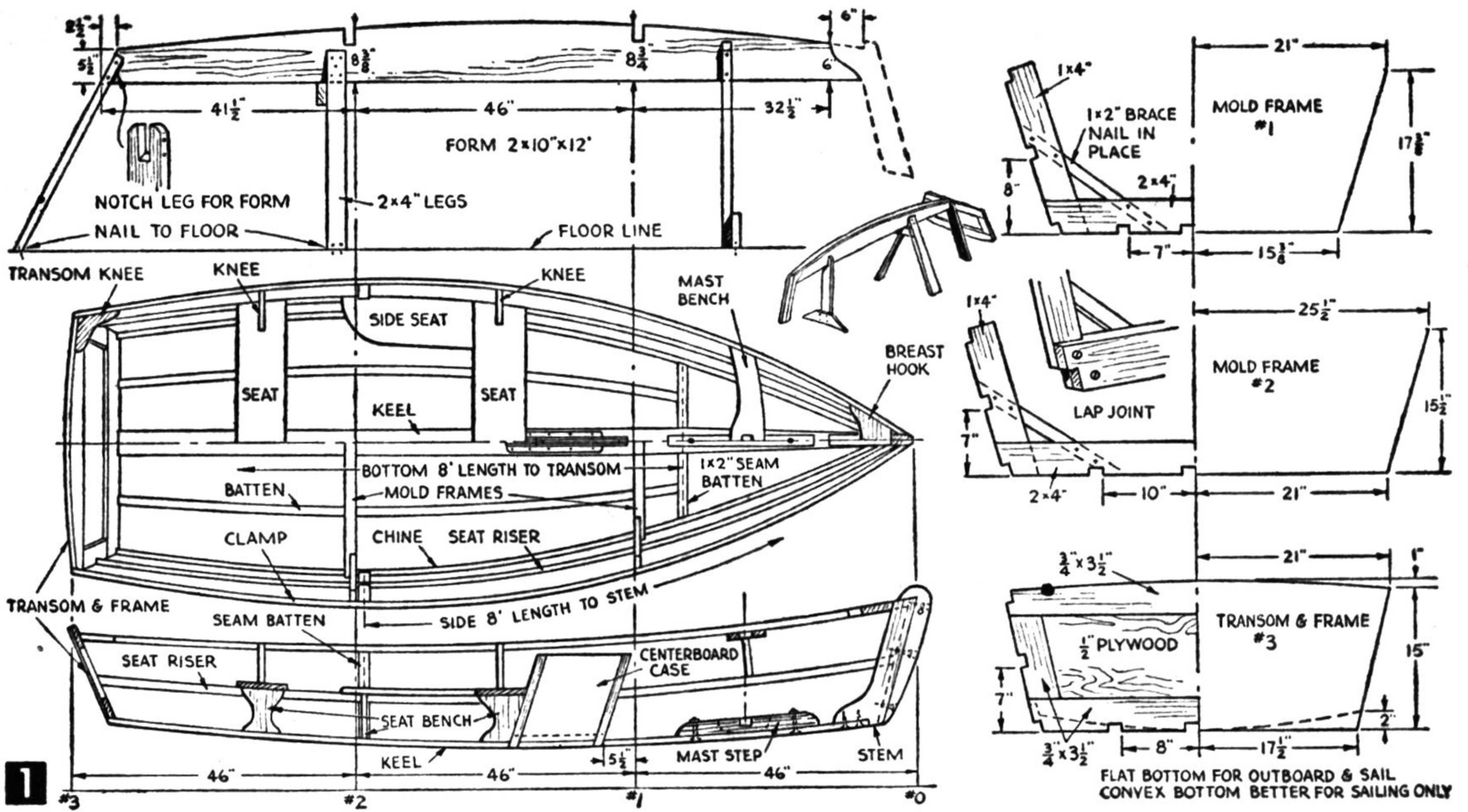

MATERIALS LIST—BREEZE-BABY

PLYWOOD		1 pc. $\frac{3}{4}$ x $7\frac{1}{2}$ " x 12"	All seats	10	$\frac{3}{16}$ x 3" Rh. stove bolts (bed logs)
1 pc. $\frac{1}{4}$ " x 4' x 12'	Sides (full length)	1 pc. $1\frac{5}{8}$ x 8' x 24"	Stem	2	$\frac{3}{16}$ x $2\frac{1}{2}$ " bolts
1 pc. $\frac{1}{4}$ " x 4' x 8'	Sides (jointed)	1 pc. 2 x 10 x 12'	Form	2	$\frac{1}{4}$ x 4" Carriage bolts (mast step)
1 pc. $\frac{1}{4}$ " x 4' x 4'		1 pc. 1 x 4 x 6'	Mold frames sides	1 lb.	Weldwood Resin glue
1 pc. $\frac{3}{8}$ " x 4' x 8'	Bottom	1 pc. 2 x 4 x 8'	Mold frames bottoms	1 pint	Kuhls bedding composition
(waste from bottom makes $\frac{1}{2}$ of fore end planking)		1 pc. Waste from form	Mast step	1 gal.	Firzite—clear or white
1 pc. $\frac{3}{8}$ x 15 x 36"	Fore end plank	1 pc. $\frac{3}{4}$ x $7\frac{1}{2}$ " x 6'	Knees, breast hook, seat benches	2	$\frac{3}{4}$ " Pintle & plate gudgeon (rudder)
1 pc. $\frac{1}{2}$ x 16 x 42"	Transom	2 pcs. $\frac{3}{4}$ x 3" x 16'	Mast	2	Junior or petite turnbuckles (stays)
1 pc. $\frac{3}{8}$ x 16 x 36"	Centerboard case	1 pc. $\frac{3}{4}$ x $\frac{3}{4}$ " x 16'		2	$\frac{1}{8}$ x $\frac{3}{4}$ x 4" Brass upper tangs (stays)
1 pc. $\frac{3}{8}$ x 12 x 42"	Board	1 pc. $\frac{3}{4}$ x 1" x 16'		1	$\frac{1}{4}$ " size lower tangs (stays)
1 pc. $\frac{3}{8}$ x 12 x 36"	Rudder	1 pc. 2 x 4 x 18" (heel)		1	$\frac{3}{8}$ x 1" Sheave (from old block)
LUMBER		2 pcs. $\frac{3}{4}$ x $17\frac{1}{8}$ " x 10'	Boom	1	$\frac{3}{16}$ x $2\frac{1}{4}$ Rh. stove bolt (sheave)
2 pcs. $\frac{3}{4}$ x $13\frac{1}{4}$ " x 12'	Chines	1 pc. $\frac{3}{4}$ x $7\frac{1}{2}$ " x 42"	Mast bench	1	Sliding mast plate goose neck
2 pcs. $\frac{3}{4}$ x $1\frac{1}{4}$ " x 12'	Seat risers	1 pc. $1\frac{1}{4}$ x $5\frac{1}{2}$ " x 24"	False stem	35 ft.	$\frac{1}{8}$ " wire rope (stays)
2 pcs. $\frac{3}{4}$ x $1\frac{1}{4}$ " x 12'	Clamps			4	$\frac{1}{8}$ " wire rope thimbles (stays)
1 pc. $\frac{3}{4}$ x 4" x 12'	Keel	2 gr. 1" #8 Fh. screws		80 ft.	$\frac{1}{4}$ " manilla rope (halyard & sheet)
2 pcs. $\frac{3}{4}$ x $1\frac{1}{4}$ " x 8'	Bilge battens	2 gr. $\frac{7}{8}$ " #7 Fh. screws		1	jig halyard block
1 pc. $\frac{3}{4}$ x 3" x 10'	Transom frame	1 gr. $1\frac{1}{4}$ " #8 Fh. screws		2	$\frac{3}{16}$ " screw pin shackle
2 pcs. $\frac{3}{4}$ x $1\frac{1}{4}$ " x 12'	Moldings	2 doz. 2" #10 Fh. screws		1	4" cleat
		5 doz. $1\frac{3}{4}$ " #8 Fh. screws		3	$\frac{1}{4}$ " screw eye (boom & traveler)
				6 ft.	$\frac{1}{8}$ " flexible wire rope (traveler)
				2	$\frac{1}{4}$ " blocks (sheet)
				12 ft.	sailtrack and screws

ment for all waterproof plywood, *don't* buy it.

Before starting on the form, notch the mold frames and transom for the keel, chines and clamps. You can also notch out the lower stem to fit the forward end of the keel. Fig. 1 shows the outline for the building 2 x 10 in. x 10 ft. form, notched for the mold frames. Use the stem piece itself as a pattern for sawing curved end in form. Mount the form on legs at a convenient working height and set up a brace for the transom. The stem can be held in place by nailing temporary $\frac{3}{4}$ x 2 in. strips along each side of form and stem until hull is ready for planking.

With the form set up as a sturdy working mount, you're ready to mount the transom, mold frames and stem on the form. Clamp the transom in place and nail $\frac{3}{4}$ x 2 in. bracing strips from the mold frames to the floor to keep them aligned.

Sailing performance depends on accurately squaring and leveling the mold frames.

Laying the Keel

Lay in the $\frac{3}{4}$ x 4 in. keel first, tapering it to fit the stem (Fig. 1). Screwfasten the keel to the stem notch with two #10 x 2 in. fh screws. Drill lead holes for all screws and rub the threads with soap to aid driving. Don't fasten any members permanently to the mold frames which will be removed later. Screw small angle clips to mold frames and keel, chines and clamps to hold them together temporarily.

To keep from wringing the frame out of shape, work the beveled chines in together starting from the beveled end at the stem and working aft. Screwfasten each chine to the stem and transom with one #10 x 2 in. fh screw. Screw the chines

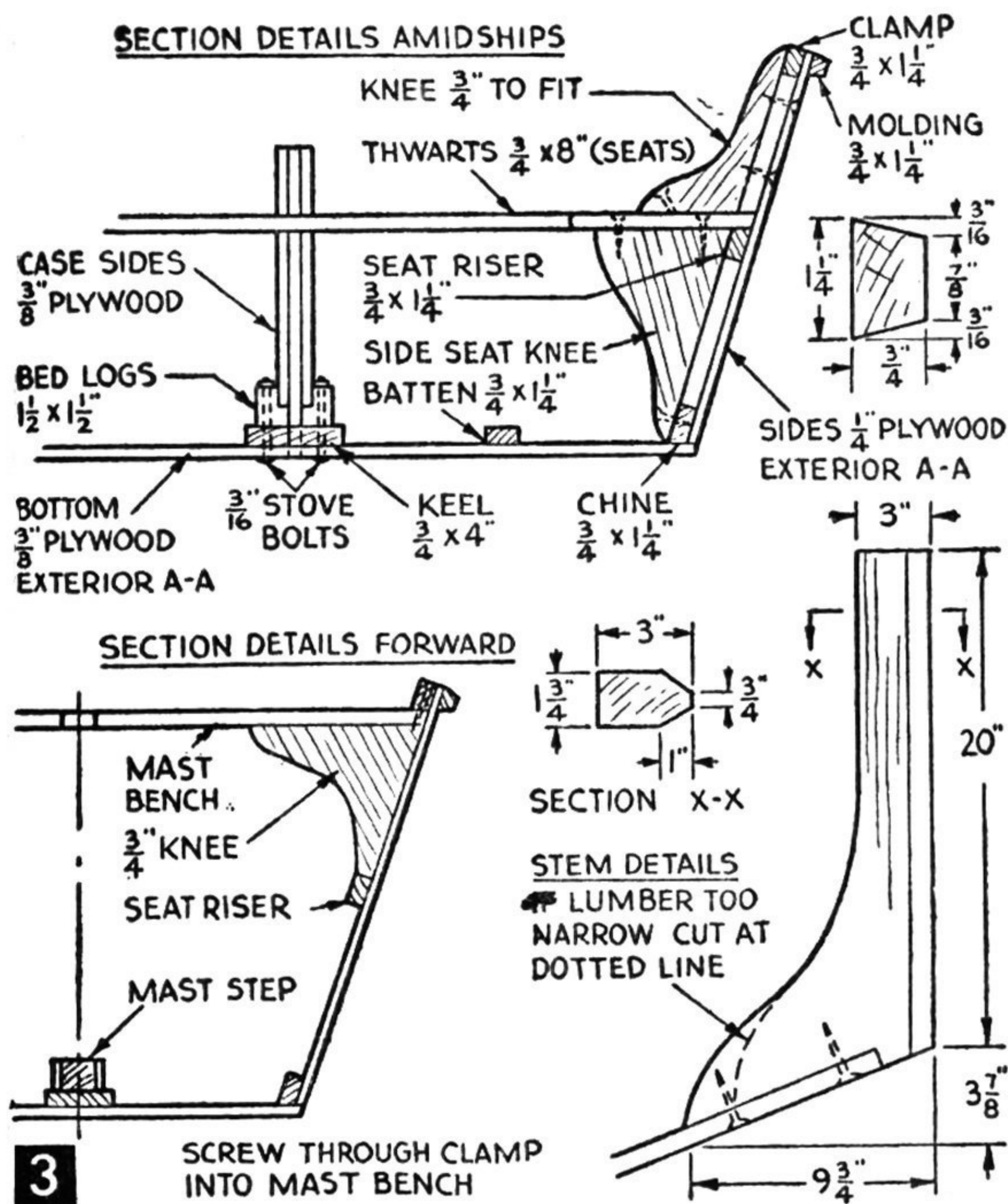

3

SCREW THROUGH CLAMP INTO MAST BENCH

to the mold frames with steel clips temporarily. The clamps are attached like the chines, working them aft from stem together to prevent wringing the frames out of shape. Fit the ends to the stem and transom and screwfasten each end with one #10 x 2 in. *fh* screw.

Place the Battens

Side battens are spaced equi-distant between chine and clamp at stem, #1 and #2 frames and transom. Taper side battens to fit stem and notch them flush into mold frames and transom. Screwfasten the side battens to the transom with one #10 x 2 in. *fh* screw and to the stem with one #8 x 1 1/4 in. *fh* screw. Level the battens and fasten to each mold frame with an iron clip.

Bottom or bilge battens are positioned equi-distant between chines and keel and curve gently along the bottom to add a strength and stiffness to the bottom structure. Screwfasten the bilge battens to the transom with one #10 x 2 in. *fh* screw in each and extend forward to butt against the bottom seam batten just aft of the mast step. Clip bilge battens to the mold frames with angle clips.

Before you start planking, you must trim and fair the entire framework so the plywood will lie flat. Apply the side planking first, using a 12-ft. length of 1/2 in. plywood if available. However, if you must use an 8-ft. length, start at the stem and back up the joint with a batten 3/4 x 2 in. on each side (Fig. 4). With either length, clamp the plywood sheet along the side and mark its shape. Unclamp the sheet from the frame and saw to the outline, allowing a little extra for later trimming. Cut another plank, using the first piece as a pattern, for the opposite side. Before applying plywood side, coat chine, side batten and clamp with *Cascophen* or *Weld-*

wood glue and coat the transom and stem with *Kuhls* bedding compo. Clamp the side plywood in place and screwfasten along all contact surfaces with #7 x 7/8 in. *fh* screws spaced at 2 in.

When both sides are planked, trim the bottom edge of the plywood evenly along the chines, stem and transom. You're now ready to plank the bottom, starting with a 4 x 8 ft. sheet of 3/8 in. plywood. Lay the sheet in position lined up with the transom and mark the bottom shape. Remove the plywood and saw it slightly larger than the mark to allow for trimming.

Before applying the bottom sheet, coat the transom edges, chines and keel liberally with *Kuhls* bedding compo followed by laying strips of muslin (a worn shirt or dress will furnish material) over coated areas. Coat the bilge battens with *Weldwood* glue and place plywood sheet in position. Screwfasten along all contact surfaces with #8 x 1 in. *fh* screws spaced at 2 in. Along the fore ends of the bottom sheet, fit in a 3/4 x 2 in. seam batten on each side of the keel. Coat the batten with *Weldwood* glue and screwfasten to the plywood with #8 x 1 in. *fh* screws spaced at 2 in. Fit two wedge-shaped pieces of 3/8 in. plywood forward to complete the bottom planking. Coat chines and keel with *Kuhls* bedding compo and screwfasten in place with #8 x 1 in. *fh* screws spaced at 2 in.

Remove from the Form

When the glue has set, you can remove the hull from the form, but leave the mold frames in position until you install the seats or, more nautically, *thwarts*. Turn the hull right side up and lay out the slot for the dagger-type centerboard (Fig. 5). Bore two 5/8 in. holes through keel and plywood to start the slot. You can start sawing with a key-hole saw and finish with a cross-cut saw. Square ends with a 1/2 in. chisel. Make up the centerboard case (Fig. 5) with end posts extending 2 in. below case. When you're sure the case fits the opening, coat the contacting surfaces between case and slot with *Kuhls* bedding compo and place in position. Bolt the case to the keel with ten 3/16 x 3 in. *rh* bolts inserted from bottom side—five bolts on each side. Place a washer under each nut and tighten them uniformly. Scrape away any excess bedding compo that squeezes out and remove the residue with

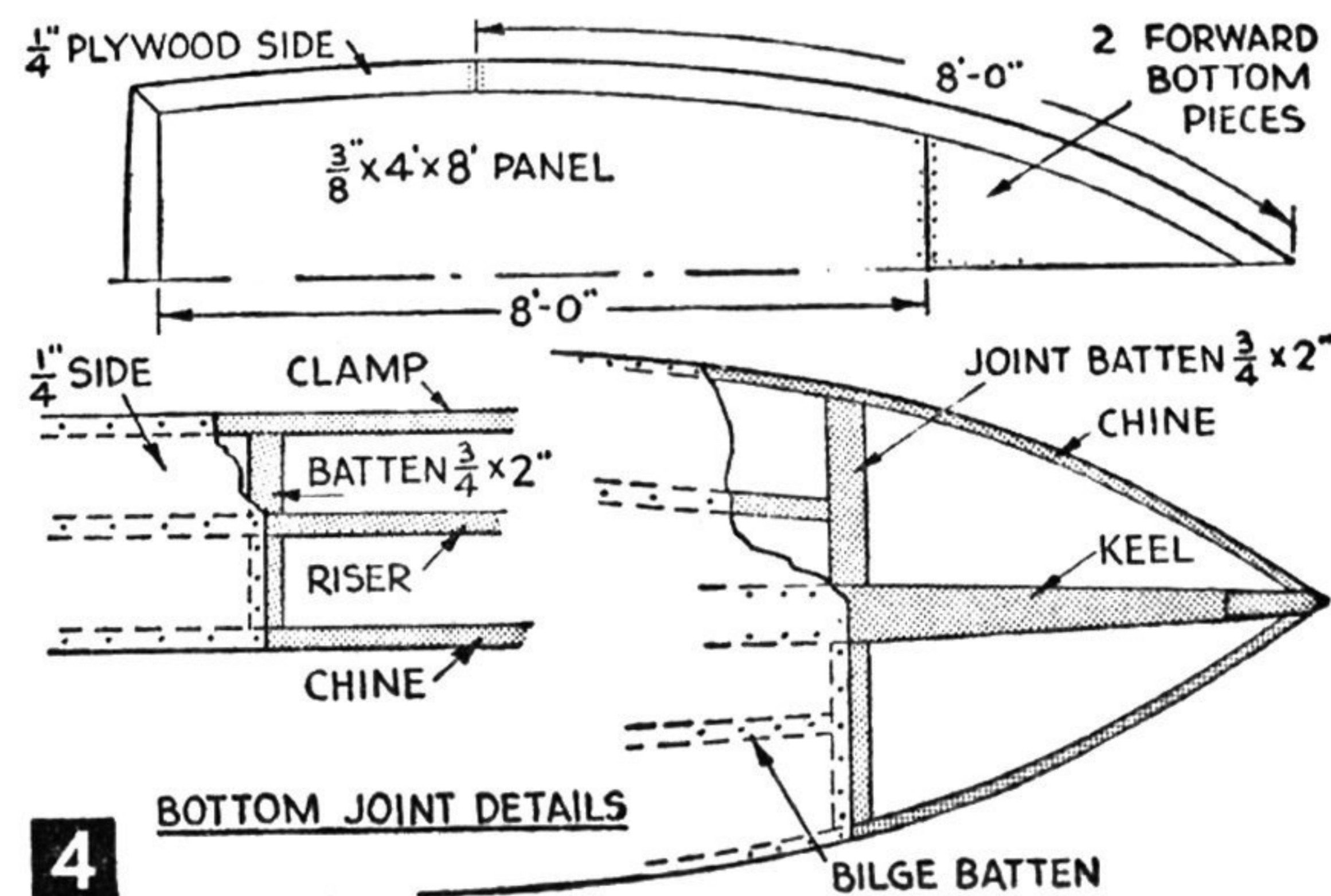

4

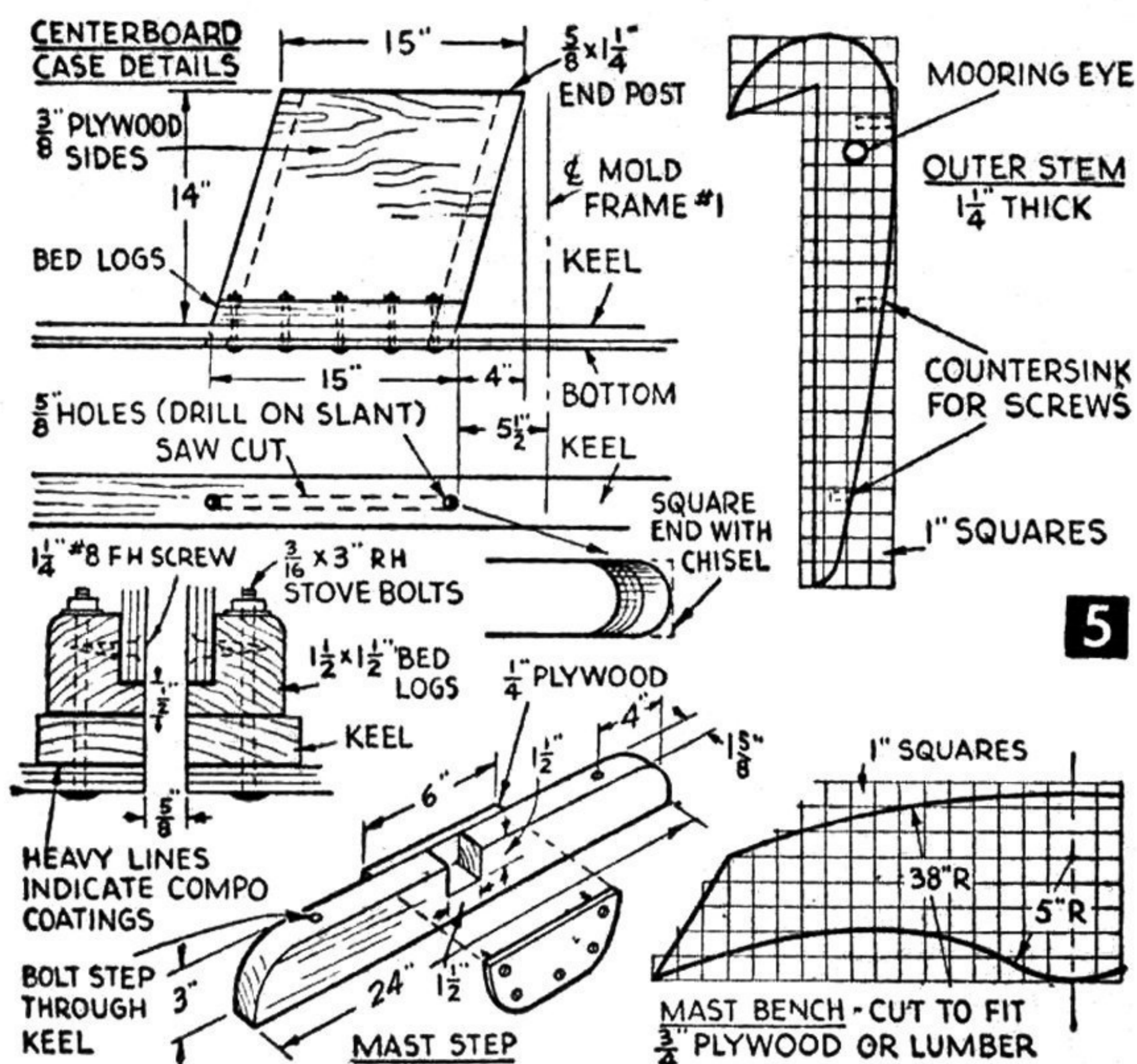

5

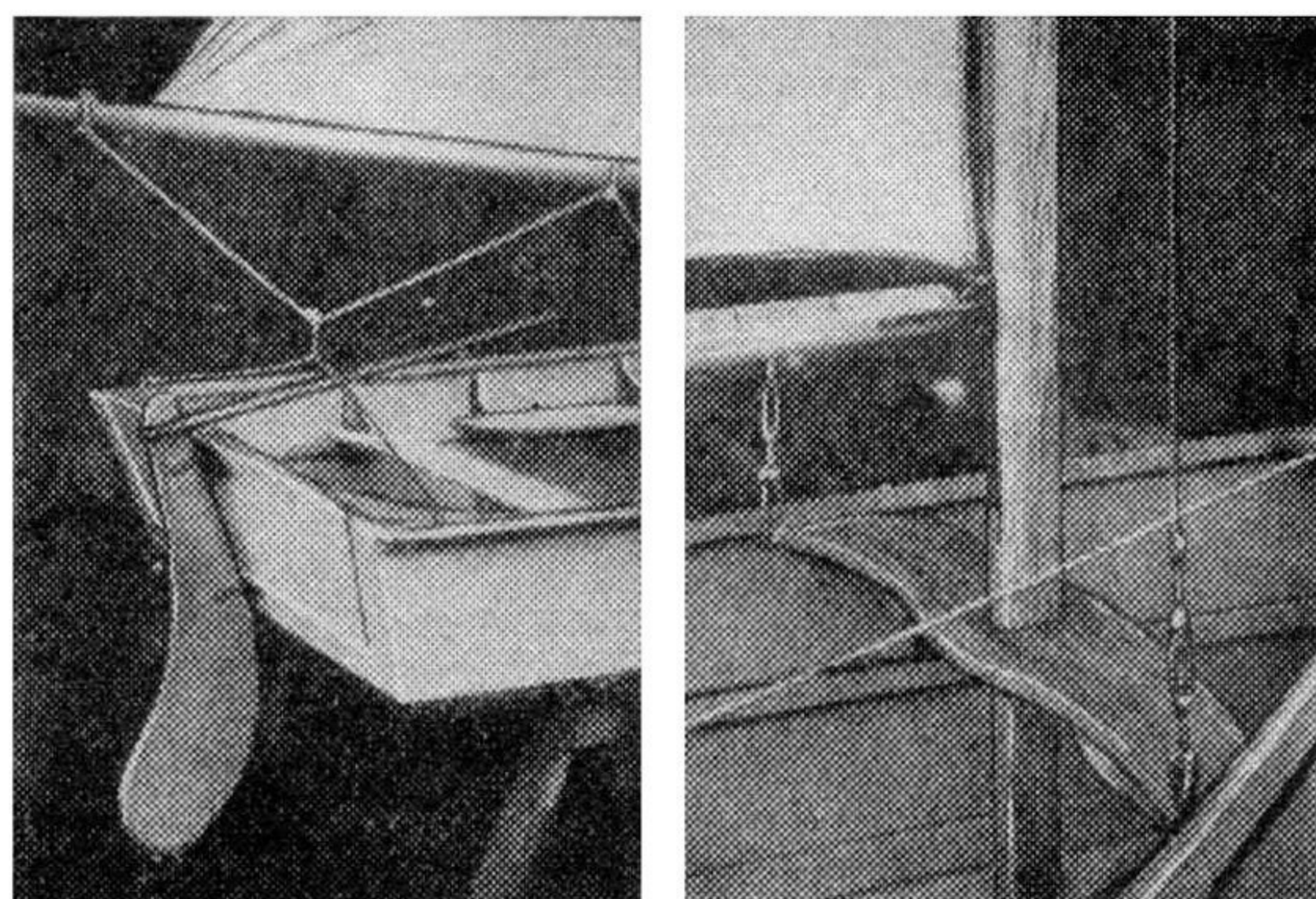

Left, rudder in place with sheet traveler rigged. Right, mast partner in place supporting mast.

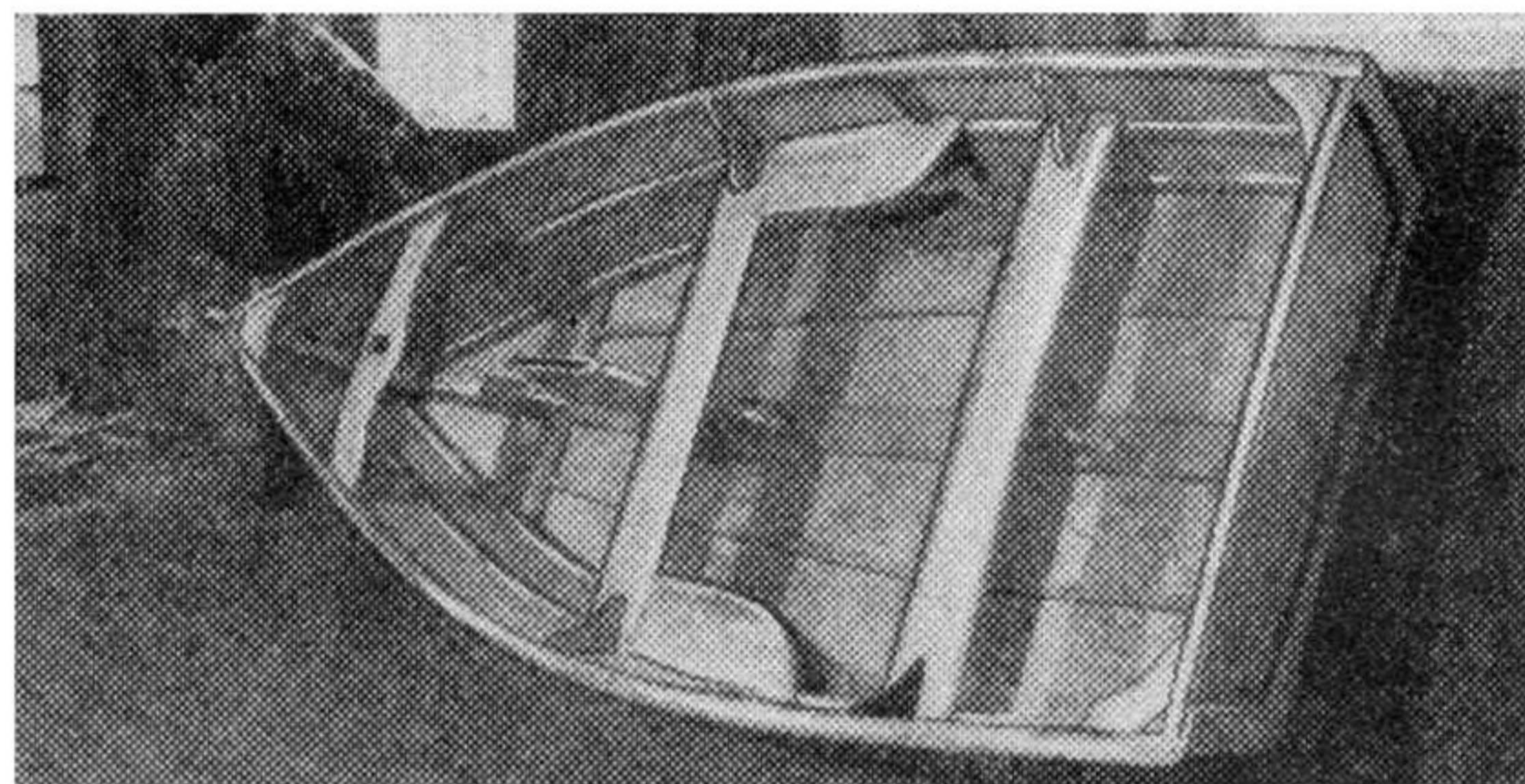

Interior with centerboard case in place.

turpentine.

The cross seats are next. Fit the $\frac{3}{4}$ in. boards to their positions, shaping the ends to conform to the sweep of the side planking. Screwfasten each end to the top of the side batten with three #8 $1\frac{3}{4}$ in. *fh* screws. Cut the curved mast bench and screwfasten it to the underside of the clamps with three #8 x 2 in. *fh* screws on each side. Before removing the mold frames, fashion the seat knees and benches and screwfasten them in place with #8 x $1\frac{3}{4}$ in. *fh* screws—three to each knee. Saw out the breasthook and transom knees, screwfastening them in place with #8 x $1\frac{3}{4}$ in. *fh* screws.

After all knees are in position, you can remove the mold frames by sawing them into two pieces over the keel. Shape the side seats and screwfasten them to side battens and knees (Figs. 1 and 3). Trim the edge of side plywood planking evenly along the top of the clamps. Cut out the false stem and screwfasten it in place with three #12 x $2\frac{1}{2}$ in. *fh* screws. Countersink the screw heads at least 1 in. deep and fill the holes with pine plugs glued in place and trimmed flush. Build up the mast step (Fig. 5) and set it in forward of the bottom planking seam batten.

The moldings can be beveled (Fig. 5) on a tilting table saw or jointer. Pilot drill the moldings for screws at 8 in. spacing and clamp in position. Pilot drill through the screw holes in the moldings to prevent splitting the clamp and screwfasten the moldings with #8 x $1\frac{3}{4}$ in. *fh* screws.

While you're working on the sailing equipment, paint the hull three coats of *Firzite*, clear if you plan to varnish the hull, or white if you plan to paint it.

Now for the Sail

Breeze-Baby is equipped with a simple cat-rigged marconi sail. The hollow mast is easy to glue up and much lighter than a solid mast. Cut out the base and top blocks to fit into the hollow end and set up level blocks with room for clamps

underneath (Fig. 2). Coat all the contacting surfaces of the mast and clamp all pieces together every 6 to 8 in. to insure complete bonding all along. If you don't have enough regular clamps, you can use two strips of wood secured with carriage bolts at each end. Allow the glue to set tightly before removing the clamps. You can build up the boom in the same way, except that it is not hollow.

Make up the rudder and tiller assembly from lumber stock or plywood and shape its cross-section as shown in Fig. 3. Attach $\frac{3}{4}$ in. pintle and plate gudgeons to match on the aft side of transom. You can make the dagger centerboard from $\frac{3}{8}$ or $\frac{1}{2}$ in. plywood. With the $\frac{1}{2}$ in. plywood, you can streamline the entering and trailing edges. The fittings for handling the sail and staying the mast should be attached as in Fig. 2.

Sail for *Breeze-Baby* is simple enough to make at home of 6 oz. sail cloth for fair results. However, the difference in sailing performance between a home-made sail and a tailor made one from a sailmaker like Alan-Clarke, 95 Chambers St., New York, N. Y. is worth the approximate cost of \$42.75. If you decide to make your own, the cross-cut design (Fig. 2) will produce the highest efficiency.