

Jon Boat

A 12-ft. Outboard Skiff for Hunting and Fishing

By WILLIAM D. JACKSON

Naval Architect

Craft Print
Project No. 311

Featherweight construction and squared ends combine to provide an easily transportable and spacious sportsman's skiff.

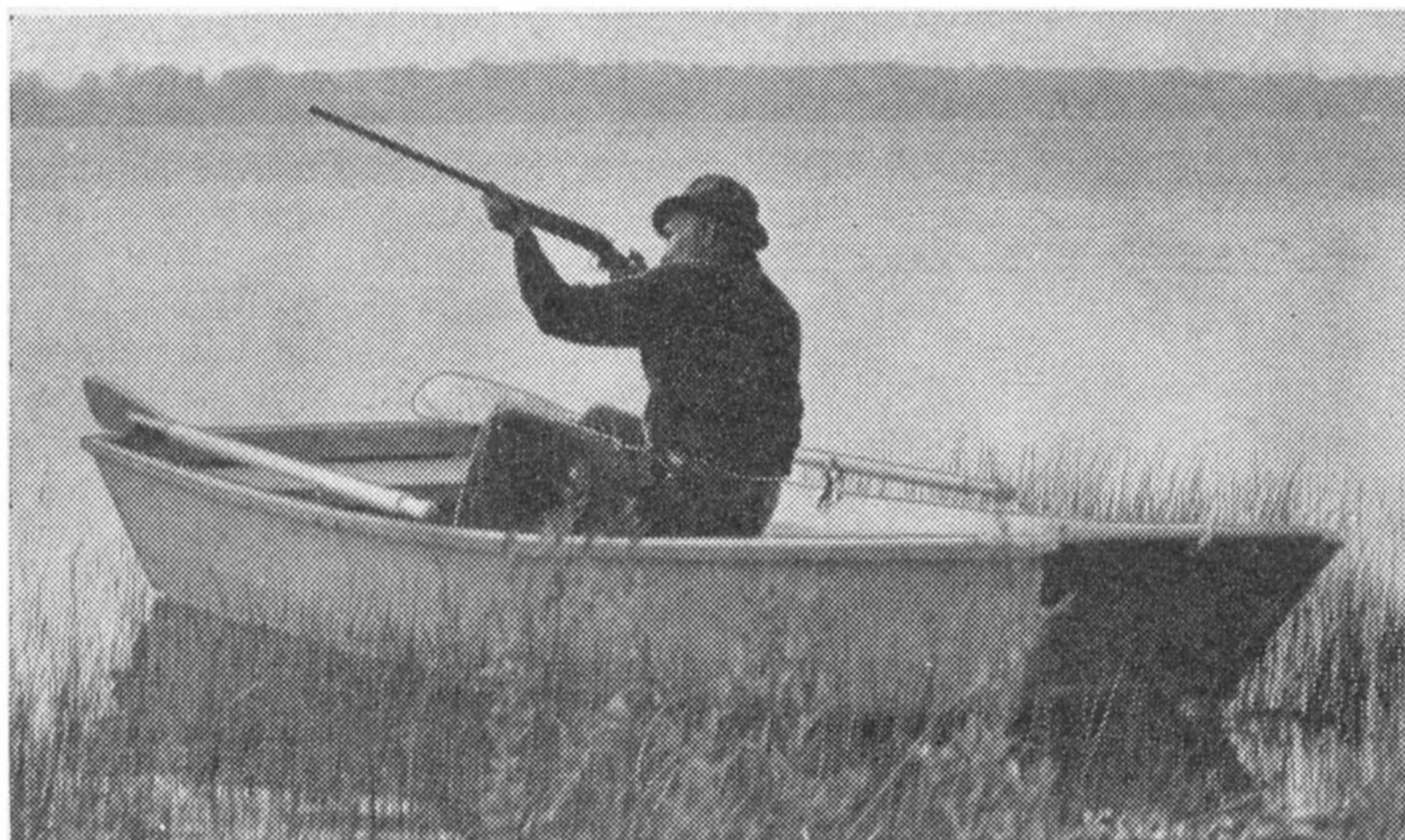
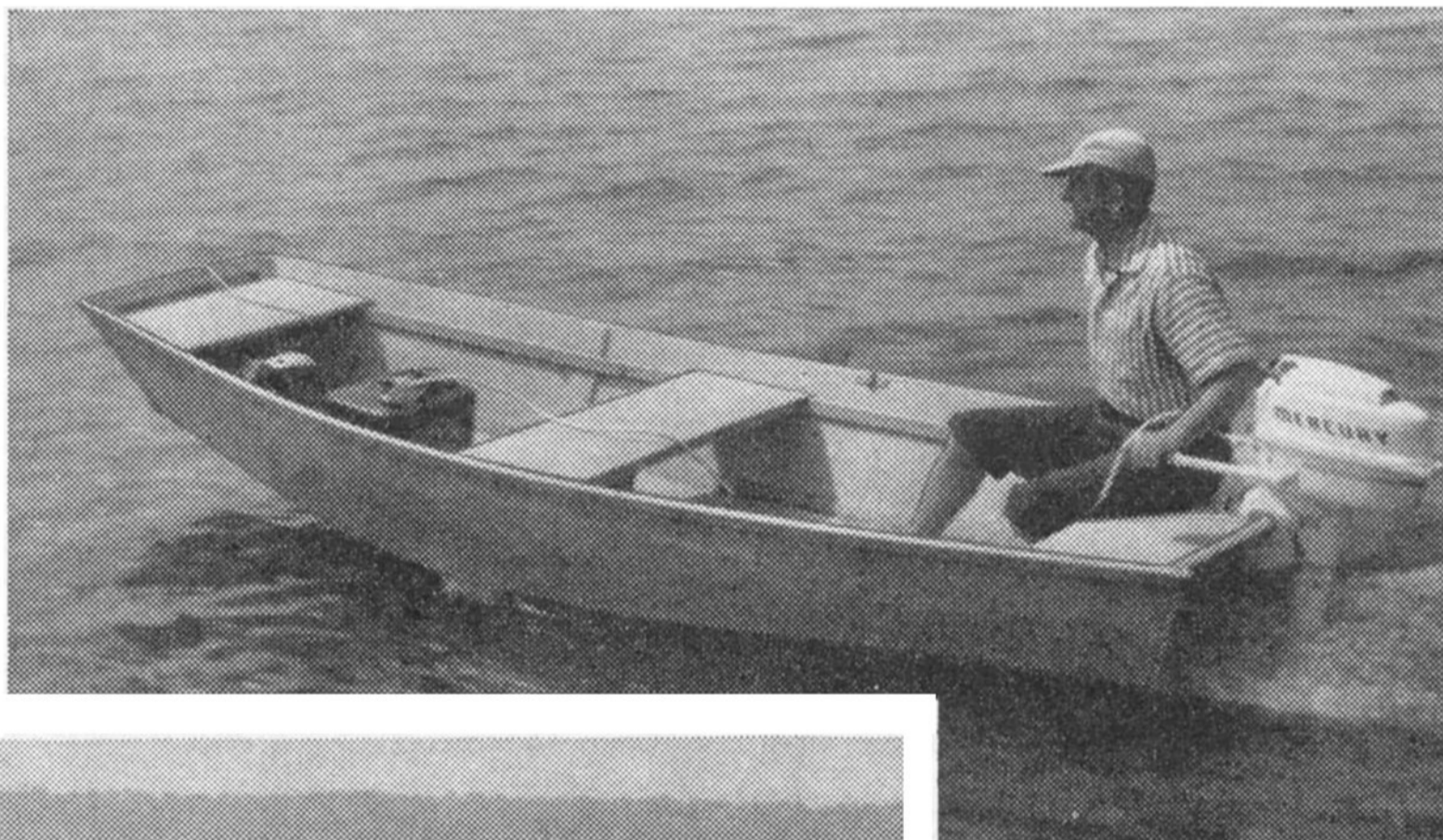

the $\frac{3}{4}$ -in. framepieces to length while they are clamped to the edges of the plywood parts. Lay out the notches for the chines, noting that the notches in the transom are cut through the frame only, while those in the stem pass through the plywood also. Cut the notches and then permanently fasten the

IF YOU want a dependable boat to poke around in rivers and marshes, this is the boat for you. And you can build it for about \$30 worth of material and two days' work.

Its design was proven before the earliest settlers brought it to America. This combined with modern simplified construction and lightweight materials gives you an extremely water-worthy boat. Add a 1-6 hp outboard motor and a car top carrier to this and you're free to go anywhere in search of fish, fowl and fun.

Start Construction by laying out full-size drawings of the transom and stem (Figs. 2 & 4) on a plywood panel and cut them out. Cut

STATEMENT OF USES

TYPE: Historical flat-bottomed skiff with squared stem and transom.

USES: Hunting, fishing and general utility car top boat.

LENGTH: 12 ft.

BEAM: 5 ft.

WEIGHT: 110 lbs.

CAPACITY: 3-5 adults.

CONSTRUCTION: AC exterior plywood panels formed over wooden frames.

POWER: 1-6 hp outboards.

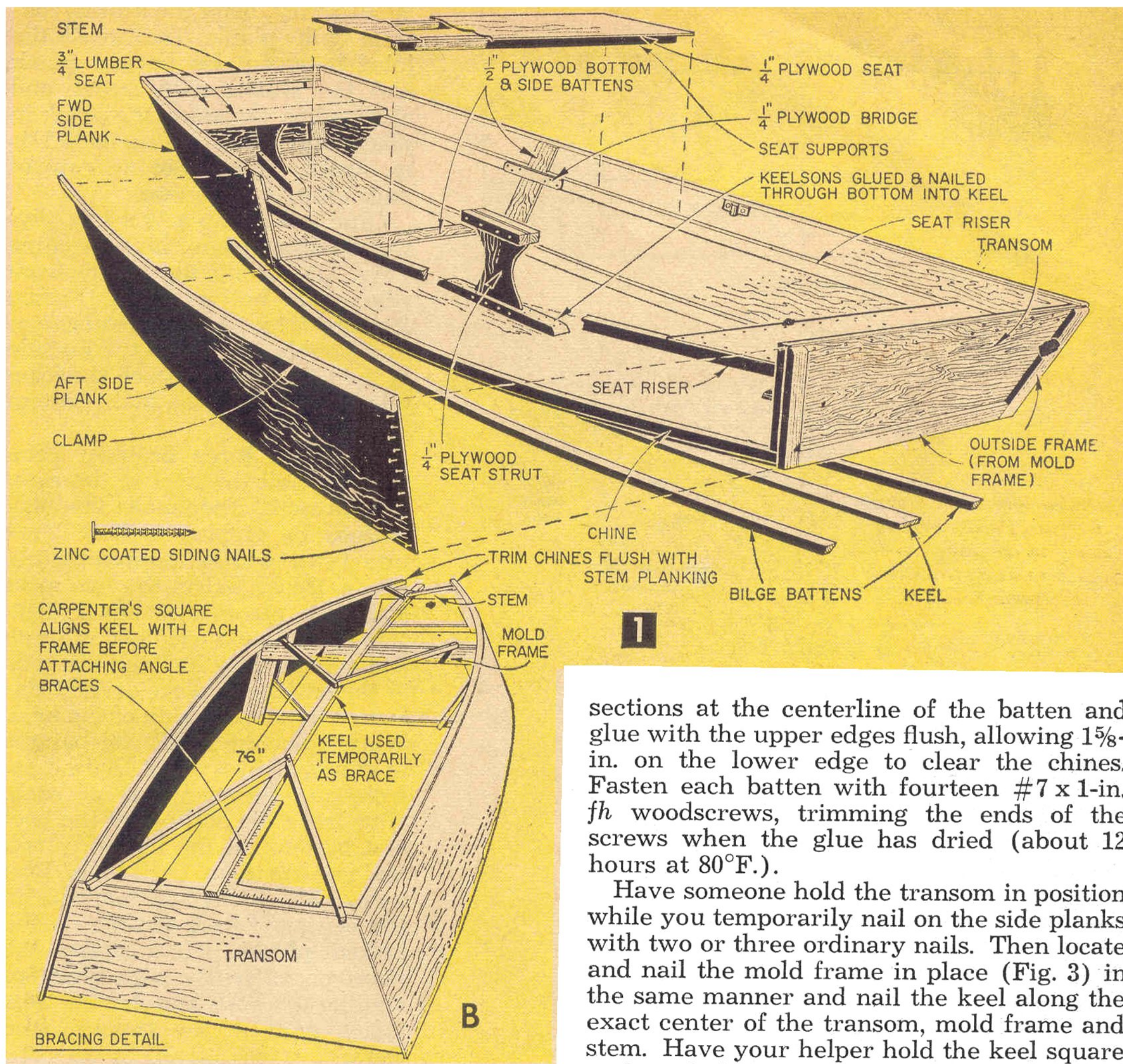

sections at the centerline of the batten and glue with the upper edges flush, allowing 1 5/8-in. on the lower edge to clear the chines. Fasten each batten with fourteen #7 x 1-in. fh woodscrews, trimming the ends of the screws when the glue has dried (about 12 hours at 80°F.).

Have someone hold the transom in position while you temporarily nail on the side planks with two or three ordinary nails. Then locate and nail the mold frame in place (Fig. 3) in the same manner and nail the keel along the exact center of the transom, mold frame and stem. Have your helper hold the keel square with each frame (Fig. 1B) while you attach angle braces to maintain proper alignment during construction.

Run a rope around the planks near each end of the hull, so you can remove the end frames without disturbing the rest of the assembly. Coat the mating surfaces of the planks, chines and frames with sealer and insert 1-in. cloth strips coated with sealer in the plank joints. Now permanently assemble these parts (Fig. 1B) with 1-in. nails.

Bottom Planking. With a straightedge, draw a centerline for the main bottom plank along the length of a third plywood panel. Divide this line into four 2-ft. sections, drawing lines perpendicular to the centerline. Then mark the distance from the centerline at each 2-ft. section as in Fig. 4B. Drive nails partway at each of these points and bend a 3/4-in. batten along the nails. Draw the outline of the plank along the batten and saw to shape.

Set the bottom plank in place on the chines, holding it with a few ordinary nails while

framing to the poorest side of the plywood with glue and 1-in. ringed asbestos siding nails. Space the nails 2 in. apart and slant them about 25° for maximum holding power.

Bevel the sides and bottom of the transom and stem, and attach the 3/4-in. motor-board to the transom with 1-in. siding nails. Use an iron bar as a dolly to support the plywood while nailing and clinching exposed nail ends.

Assemble the Mold Frame (Fig. 2A) from 3/4-in. stock, using ordinary nails to allow the lumber to be salvaged when the mold frame is no longer needed. Connect the frame at the top with a 3/4 x 1-in. crossbrace and add angle braces at each side to increase rigidity.

Cut a second plywood panel into three 16-in. widths. Lay out and cut the stern angle on two of these (Fig. 4A) and cut the third width into two 4-ft. lengths with the bow angle on each of these. Join the long and short sections with a 1/2-in. plywood batten (Fig. 1) to form the side planks. Join the

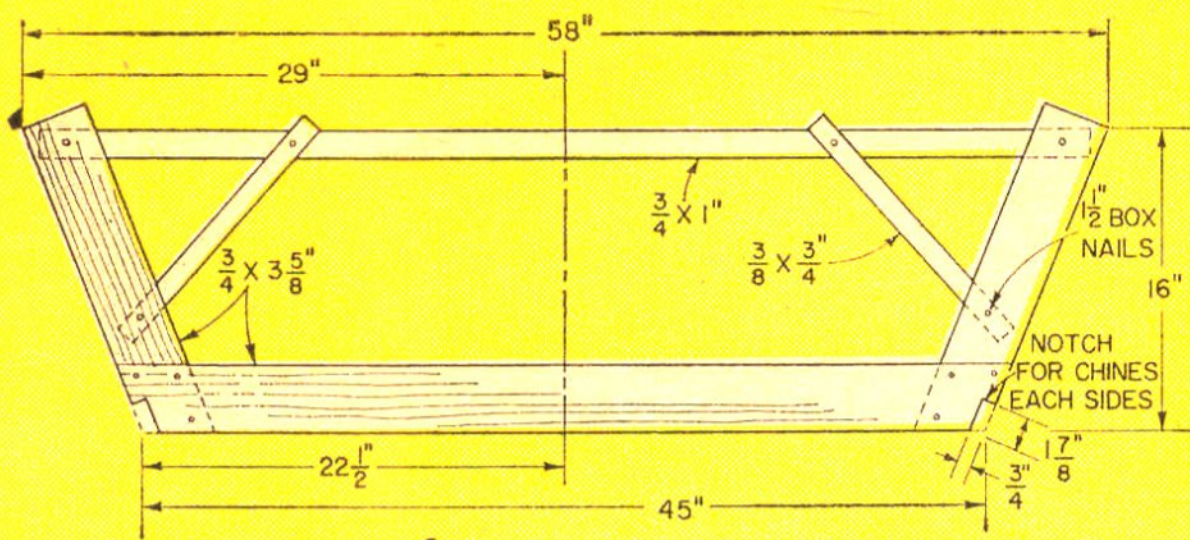

A MOLD FRAME

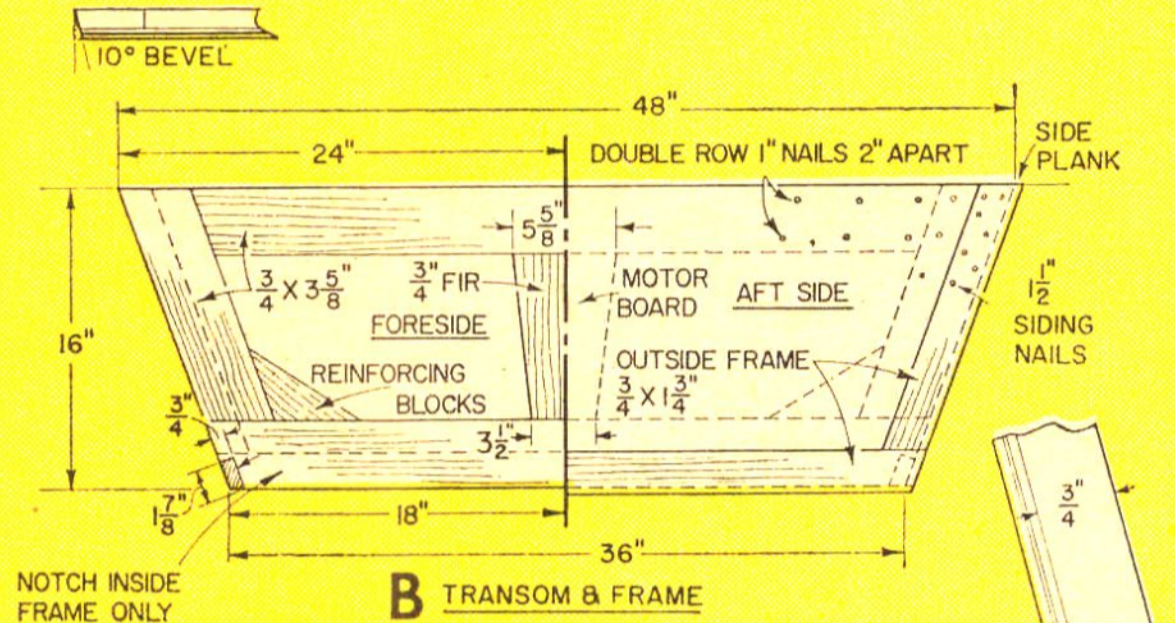

B TRANSOM & FRAME

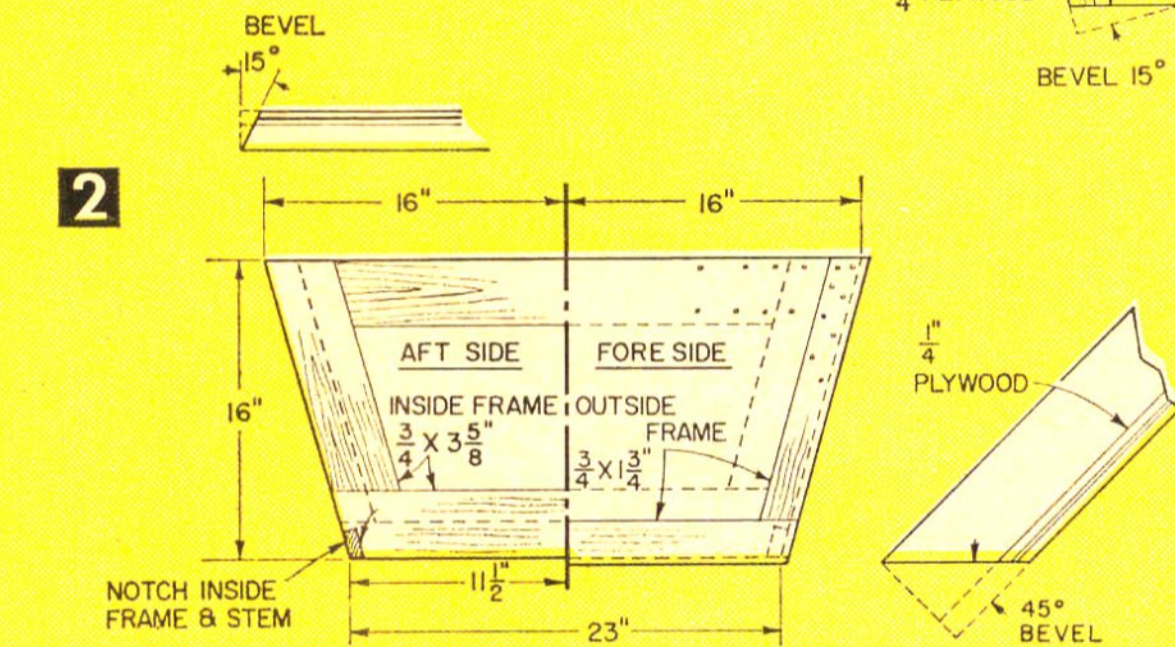

C STEM & FRAME

checking the fit. If any adjustment is necessary, bend the hull to conform to the plank. Then caulk the joint between the bottom plank and the chines with sealer and cloth strips, fastening the plank in place with 1 1/4-in. siding nails 1 1/4-in. apart. Use a double row of nails along the transom.

Glue and clamp a 1/2 x 4-in. plywood batten from chine to chine (Fig. 3D) along the inside front edge of the bottom plank. Fasten it with #7 x 1-in. fh woodscrews in a double row from the outside of the plank. Now attach the foreplank as you did the main bottom plank.

Keel and Bilge Battens. Temporarily nail the keel to the stem and transom. Then make the bilge battens by ripping a 12-ft. 2 x 4 into three widths, approximately 1 1/8-in. thick. Select the two most knot-free pieces and bevel their sides 15°. Round each end of these and temporarily nail the aft ends of the battens in place at the transom, 9 in. on each side of the keel. While someone holds the battens in place, drill a 1/4-in. hole 3 in. from the forward end of each. Now trace the outlines of the keel and battens on the bottom plank and remove them. Drill 1/16-in. lead holes (Fig. 3) at 1-ft. intervals in the center of each outline on the bottom planks. Then replace the parts permanently with glue, installing the bolts and driving 2-in. siding nails at the transom and stem.

Now turn the hull over and support it on saw horses. Draw lines through the lead holes and use them as a guide to drive 1 1/4-in. siding nails, 2-in. apart through the keel and battens. Use a staggered double row on the keel, spaced 1 1/4 in. on each side of center.

Sheer Clamps and Seats. Rip a 1 x 4 in two lengthwise to make the sheer clamps. Rabbet one side of each 1/4 x 1 1/4-in. (Fig. 3B) and glue them to the top edges of the hull. Use 1-in. nails to fasten the clamps in place, spacing them 2-in. apart and clinching their ends on the outside of the clamp. Round the ends of the clamps at the transom and stem. Run a rope around the hull a few inches behind the mold frame, remove the frame and caulk the nail holes with Plastic Wood.

Rip the seat risers (Fig. 3F) with the saw blade set for a 22° bevel. Cut two lengths to fit from the after end of the side plank batten to the transom and two more to fit from the forward edge of the batten to the stem. Bevel

MATERIALS LIST—JON BOAT

Amt. Req.	Size and Description	Use
3	1/4" x 4 x 8' AC fir exterior plywood	planking, seats, transom and stem
1	1/2 x 8 x 40" AC fir exterior plywood	side and bottom battens
1	3/4 x 10" x 6' fir	fore seat and motor-board
1	3/4 x 4 x 40" fir	fore seat
2	3/4 x 3 5/8" x 8' fir	molding and stem frame
1	3/4 x 3 5/8" x 10' fir	transom frame
1	1 5/8 x 3 5/8" x 12' fir	seat supports
3	3/4 x 3 5/8" x 12' fir	chines, clamps and keel
1	1 5/8 x 3 5/8" x 10' fir	bilge battens and keelsons
1	3/4 x 6 x 9" fir	motor board
1 lb.	1" zinc-dipped, ringed asbestos siding nails (S211A)	
2 lb.	1 1/4" asbestos siding nails (S212A)	
1/2 lb.	1 1/2" asbestos siding nails (S213A)	
1 doz.	2" asbestos siding nails (S215A). Nails available from W. H. Maze Co., Peru, Ill.	
6 doz.	#7 x 1" flathead woodscrews	
2	1/4"-20 carriage bolts with nuts and flat washers	
1 1/2 lbs.	Weldwood glue powder	
1 qt.	Neoprene boat sealer	
12 yds.	fiber glass tape and resin	
1 pr.	North River type oar locks with 6 1/2 or 7' oars	

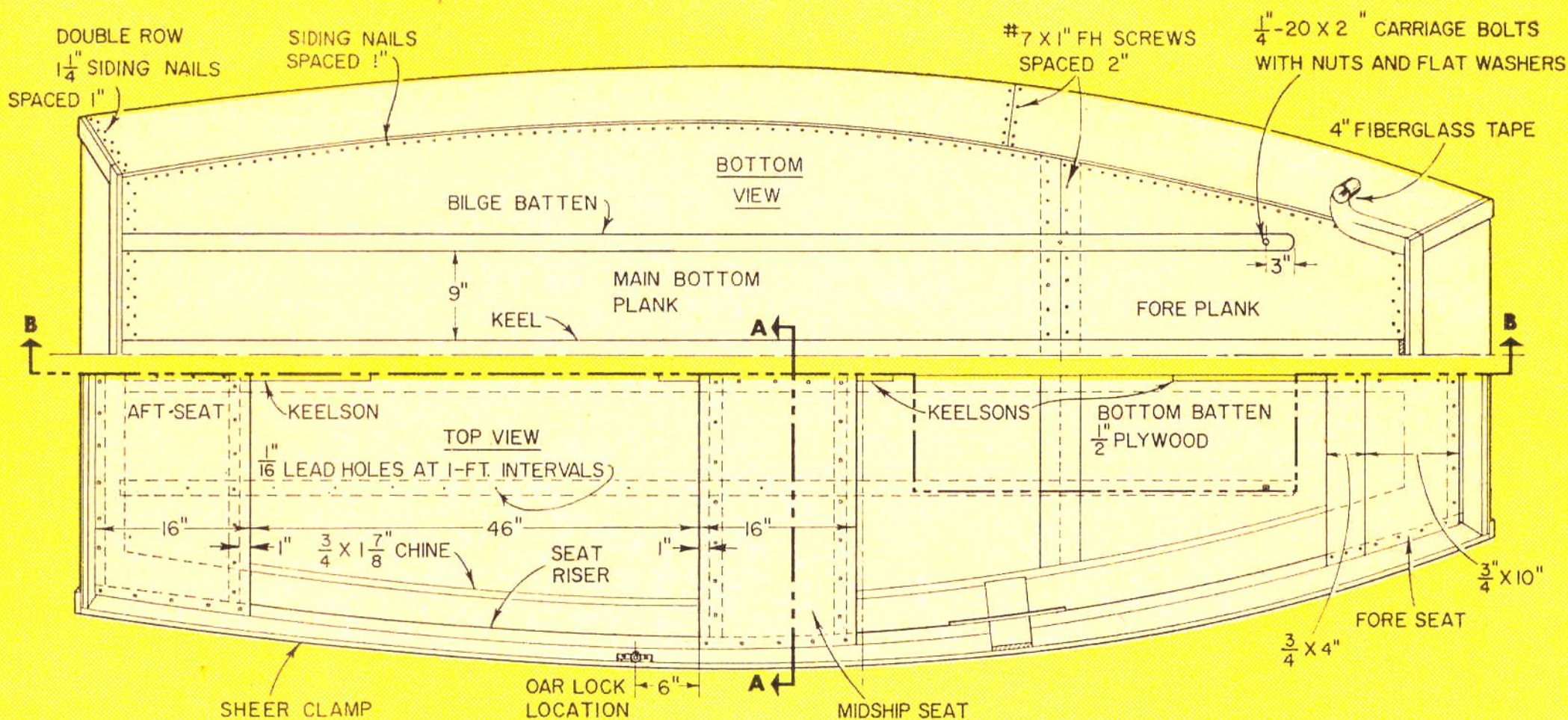

A STEM & STERN SEAT RISER

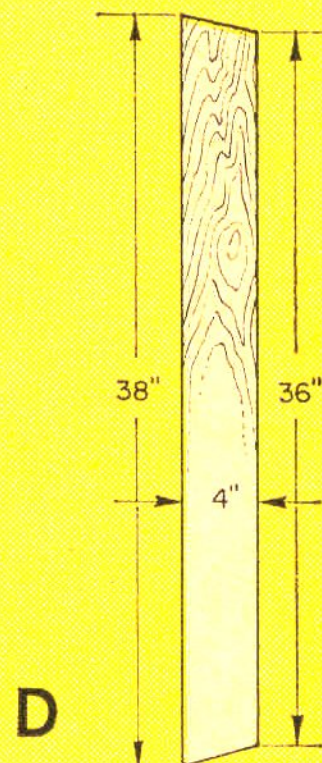
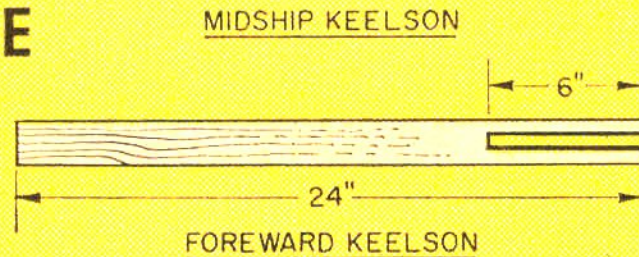
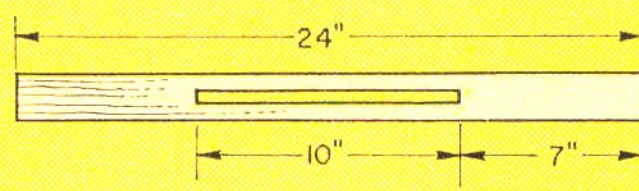
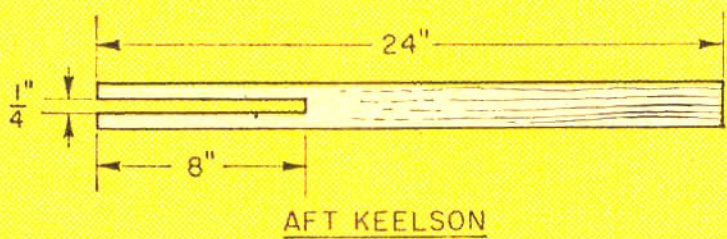
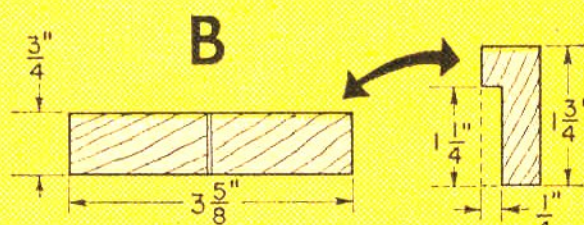
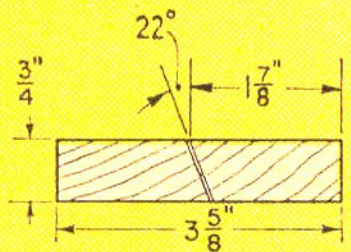
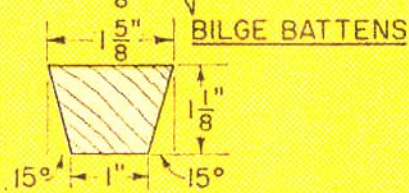
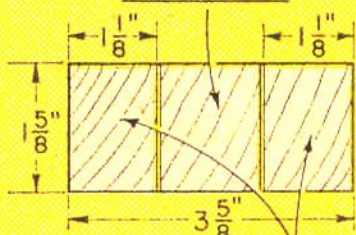

$\frac{1}{8}$ X $\frac{5}{8}$ " AFT SEAT RISER BEVELED 15°

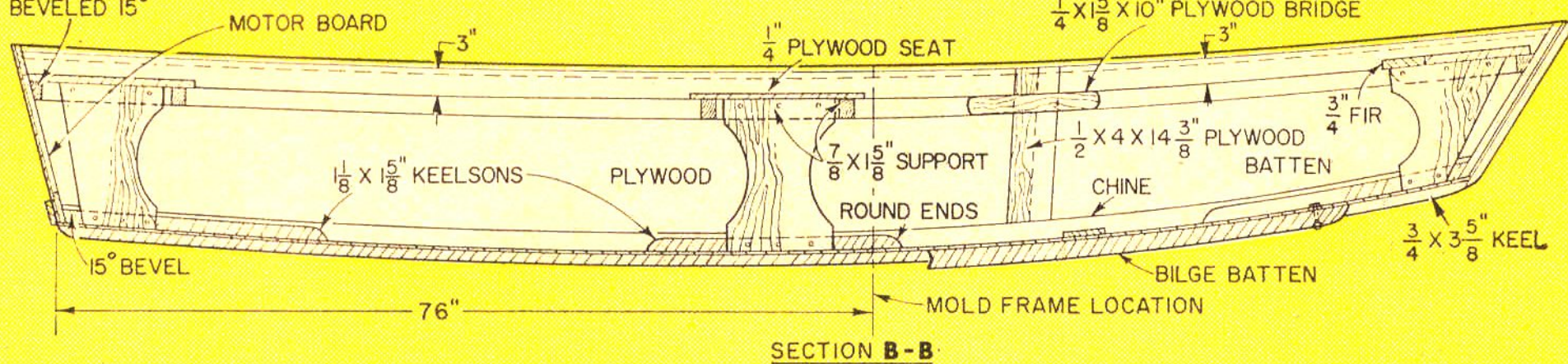

F

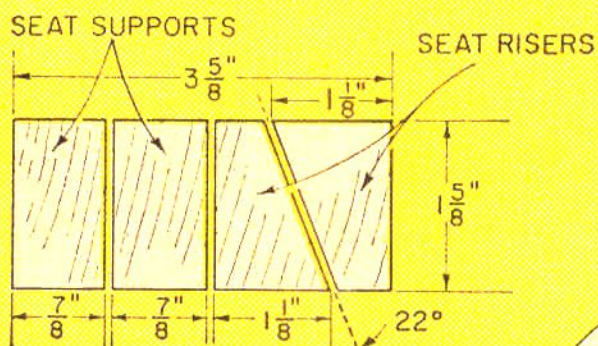

3

G

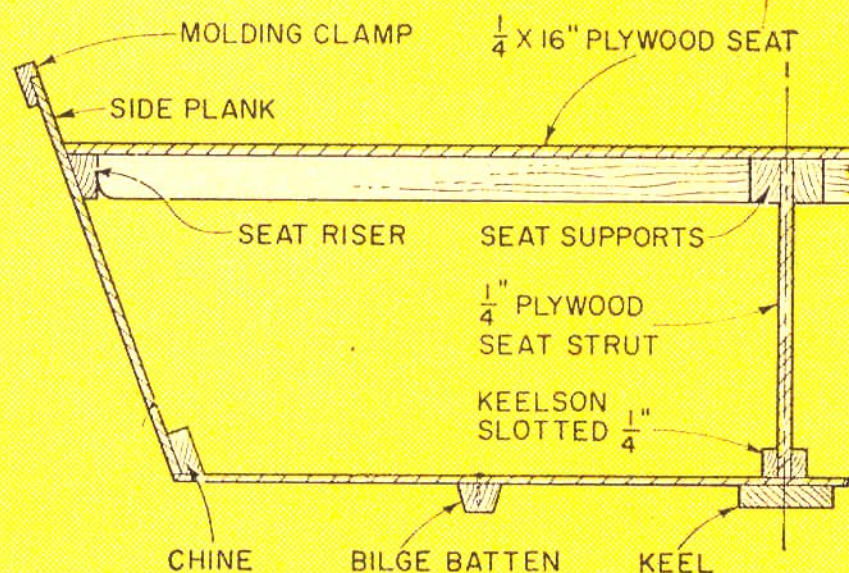
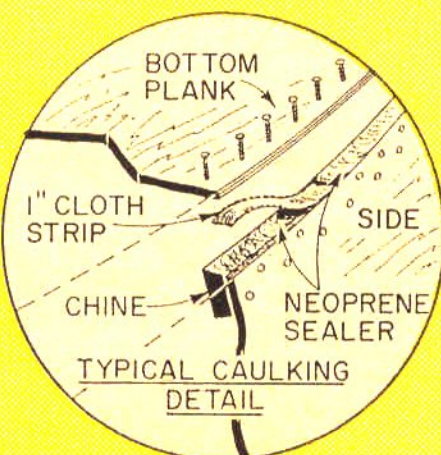

the ends of the risers to meet the frames. Glue and nail the risers from the outside with 1¼-in. siding nails, spaced 3-in. apart and bridge the side battens with a piece of ¼-in. plywood (Fig. 3), attaching it as you did the risers. Attach seat risers to the transom and stem, using 1½ x 1⅝-in. stock, beveled 15° for the transom and 45° for the stem.

Cut the aft and midship seat from the plywood panel and use a 10-in. and a 4-in. width of ¾-in. stock for the fore seat. Glue and nail 1½ x 1⅝-in. supports 1 in. from the edges of the midship and aft seats (Fig. 1). Also attach supports to the top of the seat struts (Fig. 4), cutting them to fit between the seat supports and the end risers. Cut the keelsons to length, round their ends as in Fig. 3E, and cut ¼-in. slots in them. Glue and nail the struts into these slots.

Temporarily set the seats and struts in place, allowing 46 in. between the aft and midship seats. Mark the location of the struts on the underside of the seat and on the bottom plank. Then glue and nail the strut to the seat. Finish the assembly by nailing the seat boards to the risers and the struts to the bottom plank and keel. Use 1-in. siding nails for the seat assembly and 1½-in. nails when fastening the strut to the keel.

Salvage the ¾-in. lumber from the mold frame and rip each piece in half lengthwise to provide outside framing for the transom and stem (Fig. 2B and C). Caulk this seam with sealer and cloth and then nail with 1½-in. siding nails 2 in. apart.

Trim the excess glue from all joints and be sure the nail and screw heads are flush. Clinch any protruding nails and cover the exposed plywood edges with 4-in. fiber glass tape. When dry, give the entire boat two coats of primer and one coat of your favorite marine enamel. Finally, install a pair of North River type oarlocks, 3 in. aft the midship seat edge and fit the Jon boat with a pair of 6½ or 7-ft. oars. Be sure to check with local authorities concerning small boat registration and required life-saving equipment.

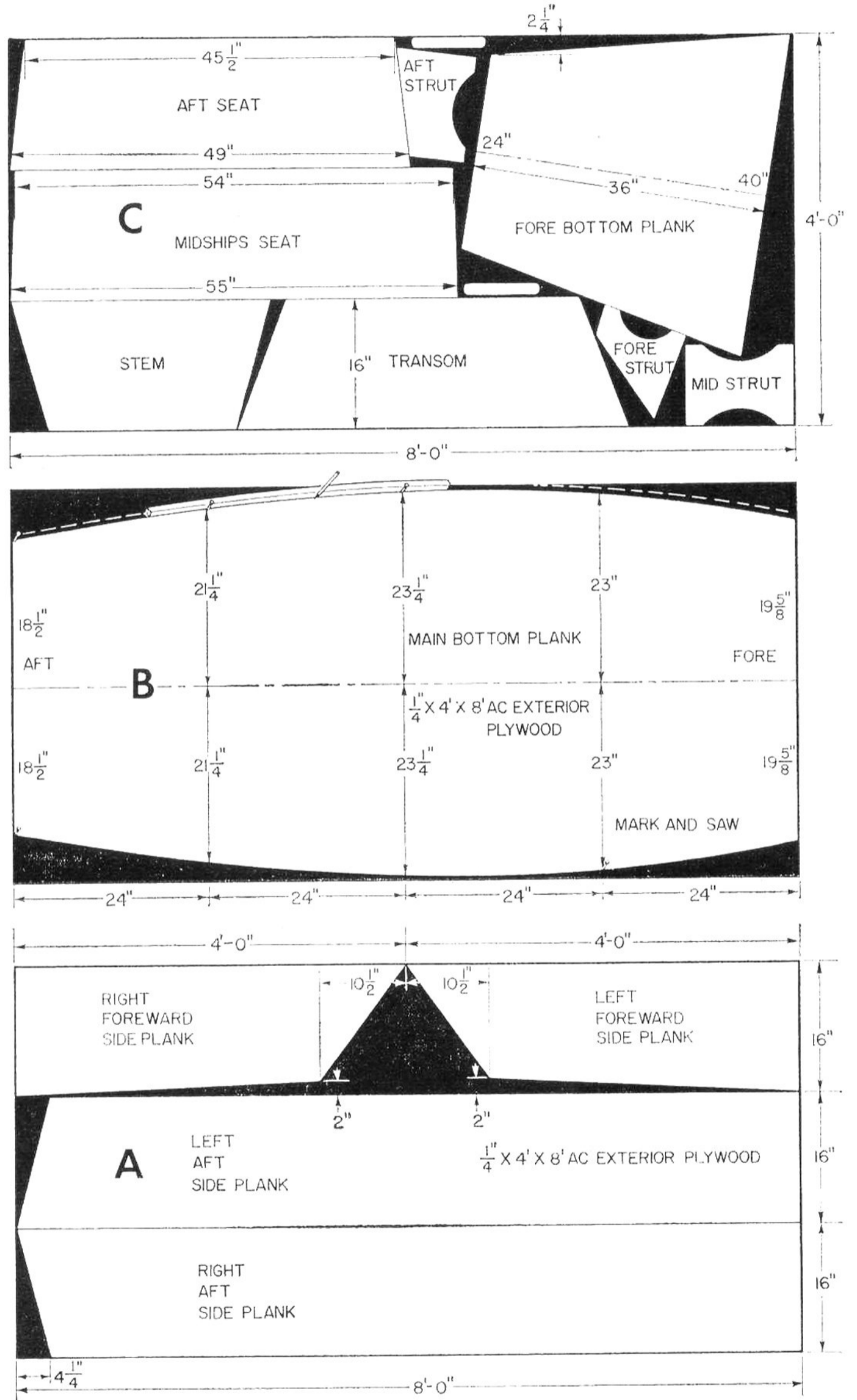
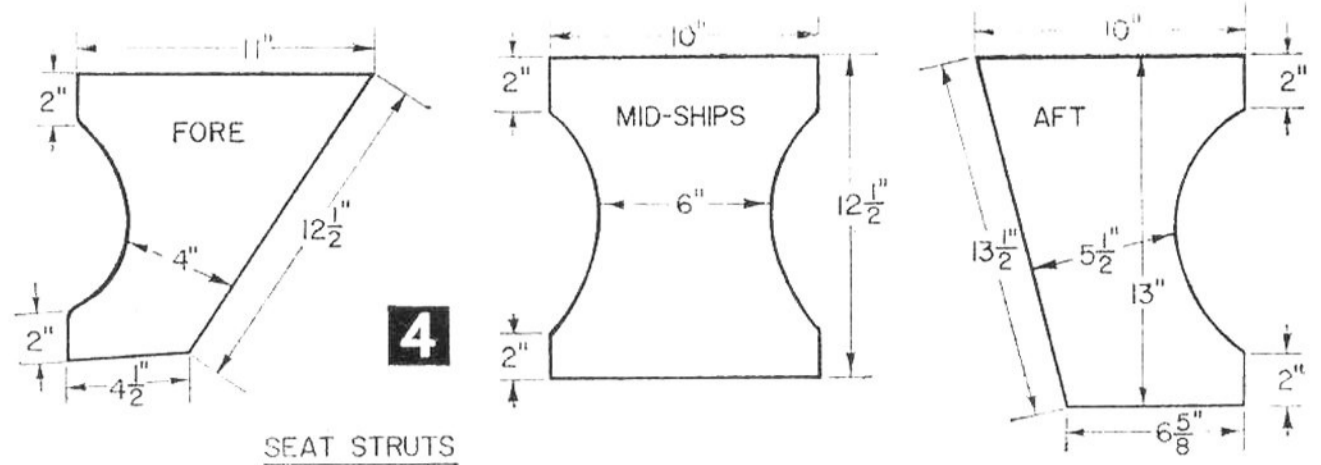

● Craft Prints in enlarged size for building outboard boats are available at \$1 each. Order by print number. To avoid possible loss of coin or currency in the mails, we suggest you remit by check or money order. (No C.O.D.'s or stamps.) Now available, our new illustrated catalog of "196 Do It Yourself Plans." 10¢, SCIENCE AND MECHANICS, 450 East Ohio Street, Chicago 11, Illinois. Please allow three to four weeks for delivery.