

PM'S PLATFORM BOAT

You can build any kind of floating fun on top of it. We give you plans for the pontoons and deck—you take it from there

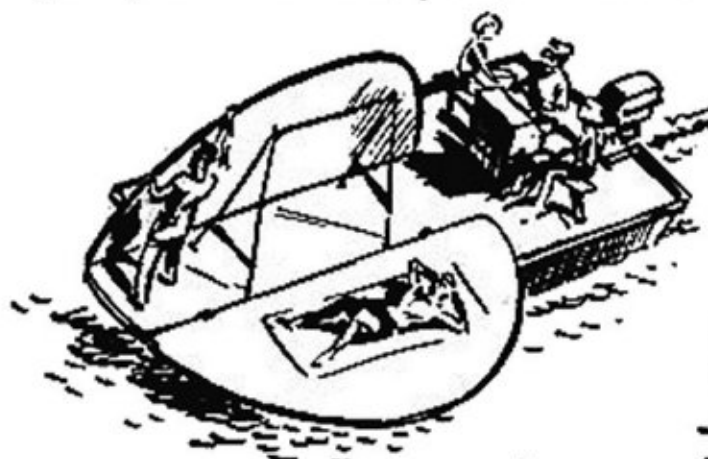

START WITH THIS easy-to-build pontoon platform and you'll have no trouble turning out a customized boat exactly suited to your needs. It's a big, roomy craft offering plenty of space for installing all the features you'd like to see in a boat.

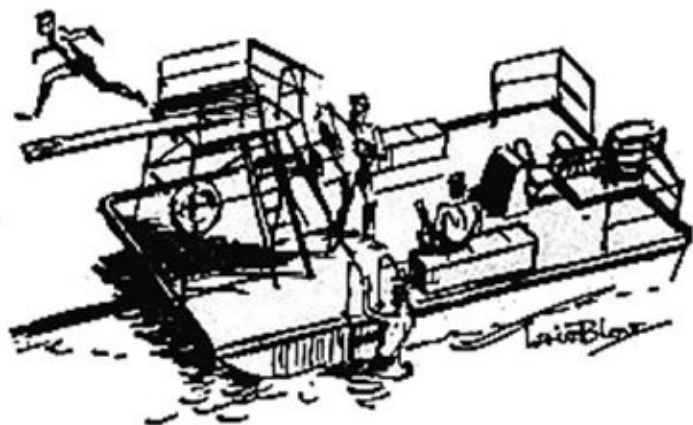
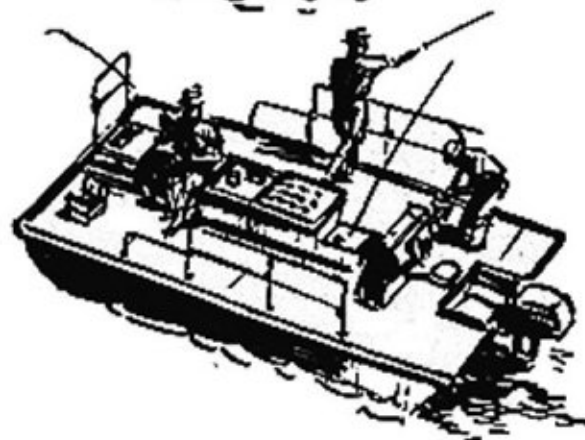

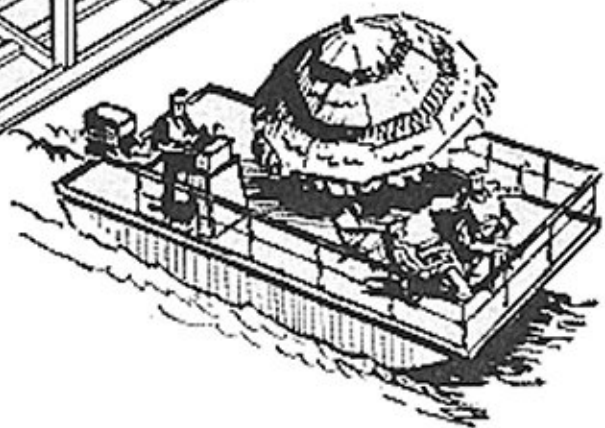
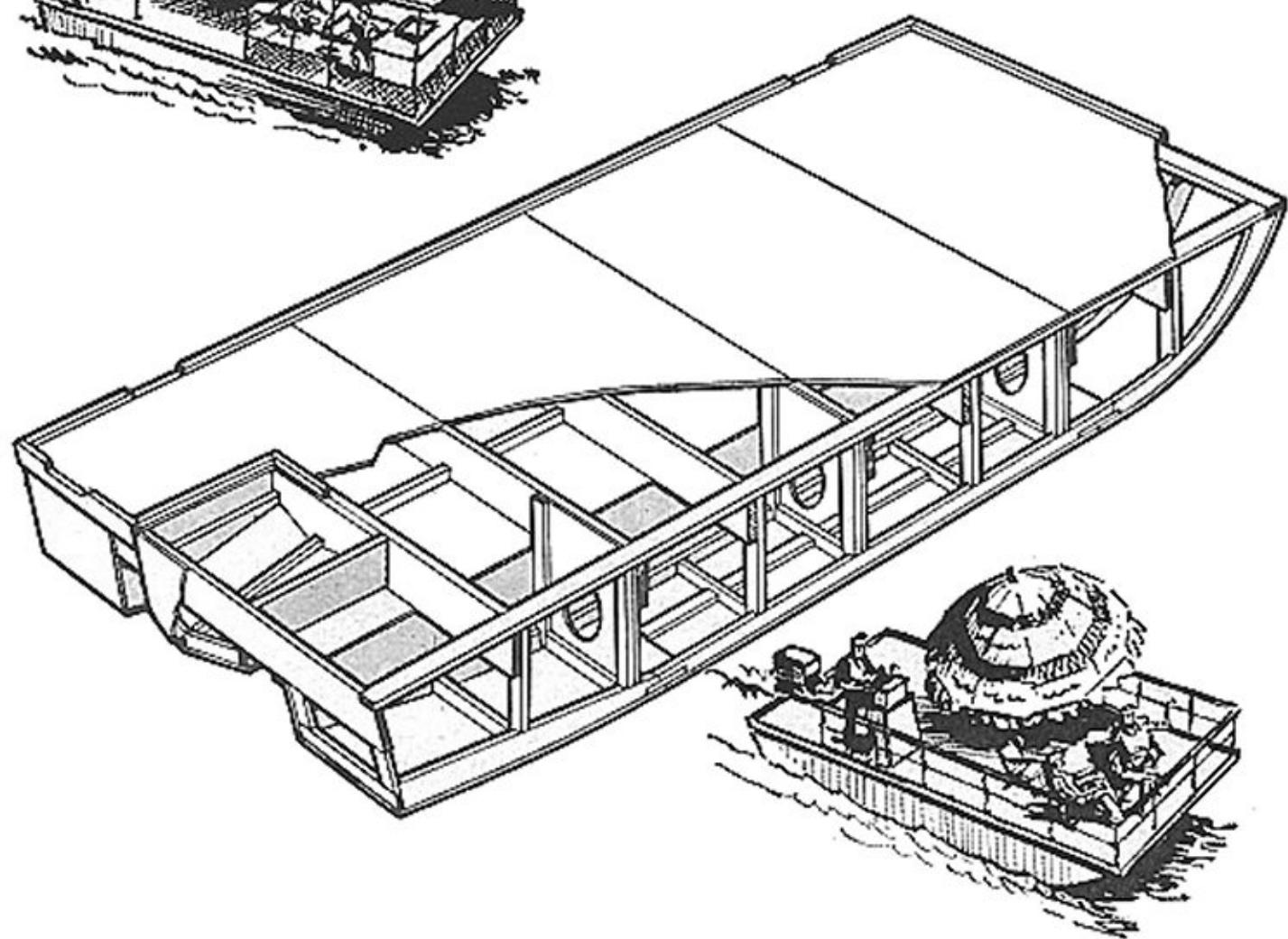
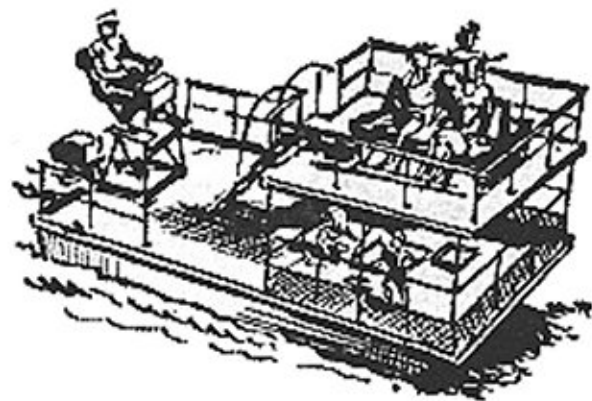

Of course, no pontoon boat is designed for towing skiers or running in really rough water, so don't try to turn it into an SK or deep-V. (Actually, this one plugs along at a stately 8 mph or so.) But outside of these limitations, this type of hull is one of the most practical choices for general use on small lakes and rivers.

Turn it into a floating picnic pavilion, with seats, table and storage space for coolers and hampers. Or, a powered fishing dock with live bait and catch wells, underdeck rod storage, fish finder and anything else necessary. Or, even a deluxe swimming station that can be moved anywhere on the lake, complete with diving tower, swimming slide and colorful dressing tents.

If you want to trailer the boat, you'll have to alter the dimensions of the pontoons. While the width falls within that permitted by regulation, the spacing between pontoons (48 in.) is too narrow to fit on a pontoon trailer, most of which re-

quire from 50 to 54 in. The 4-ft. spacing was decided upon to take advantage of stock plywood panel size and economize on materials.

By building the pontoons slightly narrower and widening the tunnel, the boat can be tailored to fit any pontoon trailer. Since it normally draws only about 4 in., the slight increase in draft caused by narrowing the pontoons shouldn't cause any problems.

General specifications. Douglas fir is satisfactory for the framing, so long as it's first grade and free of knots and shakes. For a slightly stronger boat, use white oak, Philippine mahogany or Sitka spruce. Likewise, exterior-grade plywood is satisfactory in all cases, though marine-grade will result in a stronger construction. You also have some leeway in choosing the quality plywood to be used at different locations. For example, AC panels could be used for decking with the C face down.

All joints should be glued, as well as

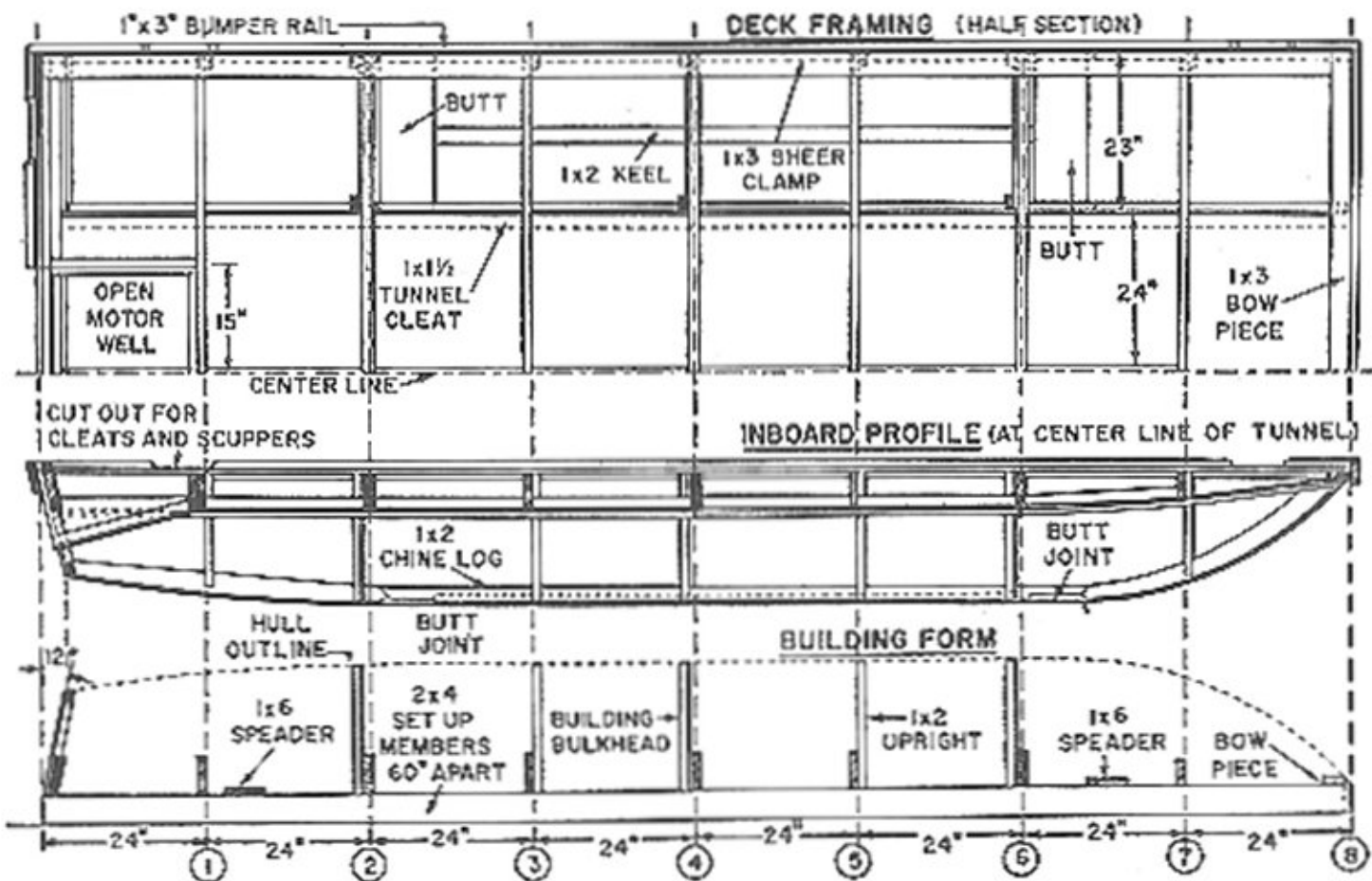

screwed or nailed. If you plan to fiberglass the hull, a hard-setting glue (resorcinol or urea-resin type) should be used. If not, however, select a mastic or flexible, water-type glue for all underwater junctions.

All fastenings should be either of bronze or hot-dipped galvanized iron. The latter are quite adequate here, and are less expensive. Incidentally, all nails should be the annular-ring type.

Review the plans and text carefully before you begin construction.

Building bulkheads. The three building bulkheads each consist of two $\frac{1}{4}$ -in. plywood bulkheads framed with 1 x 2 stock and fastened to a 2 x 6 beam. As shown in the photos, lightening holes may be cut in each of the bulkheads to reduce the weight of the boat. Limbers (drainage holes) should be cut adjacent to the keel notch to allow any bilge water to drain aft where it can be removed through drain plugs installed in the transom or pumped out, gaining access through small hatches set flush with the deck near the transom.

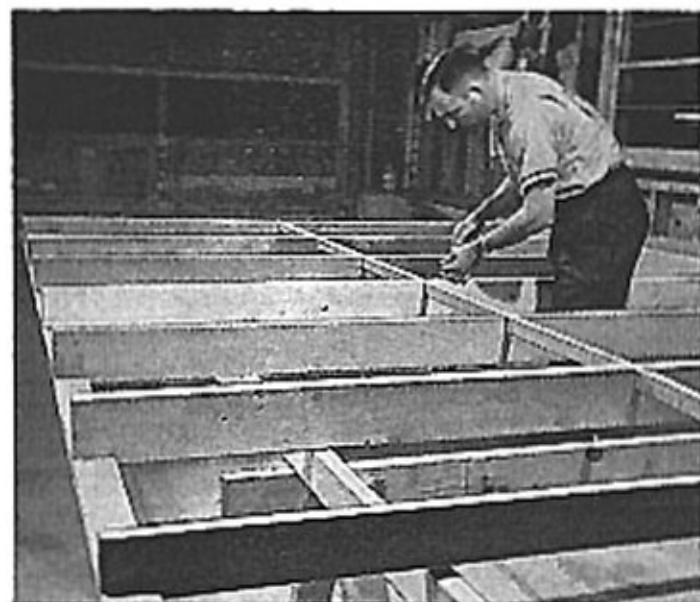

BUILDING FORM is actually just two 2 x 4 set-up rails on which the basic framing pieces are mounted

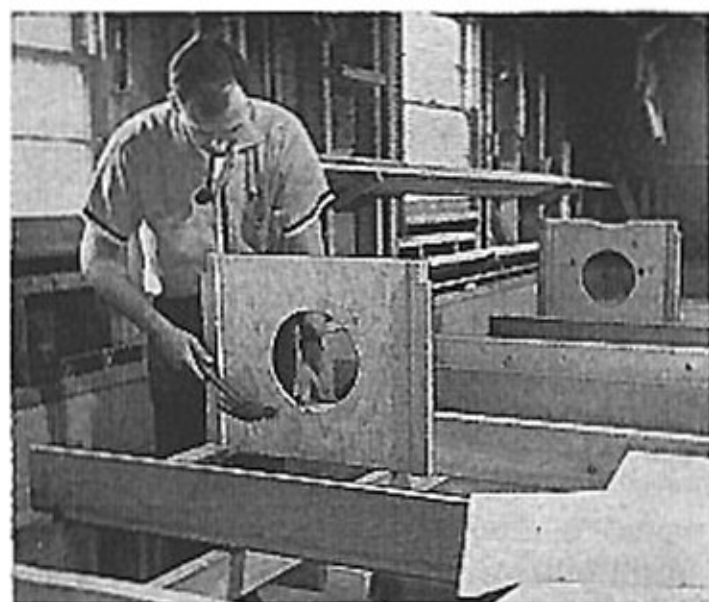

PLYWOOD BULKHEADS mounted on the 2 x 6 beams make up three building bulkheads spaced 4 ft. apart

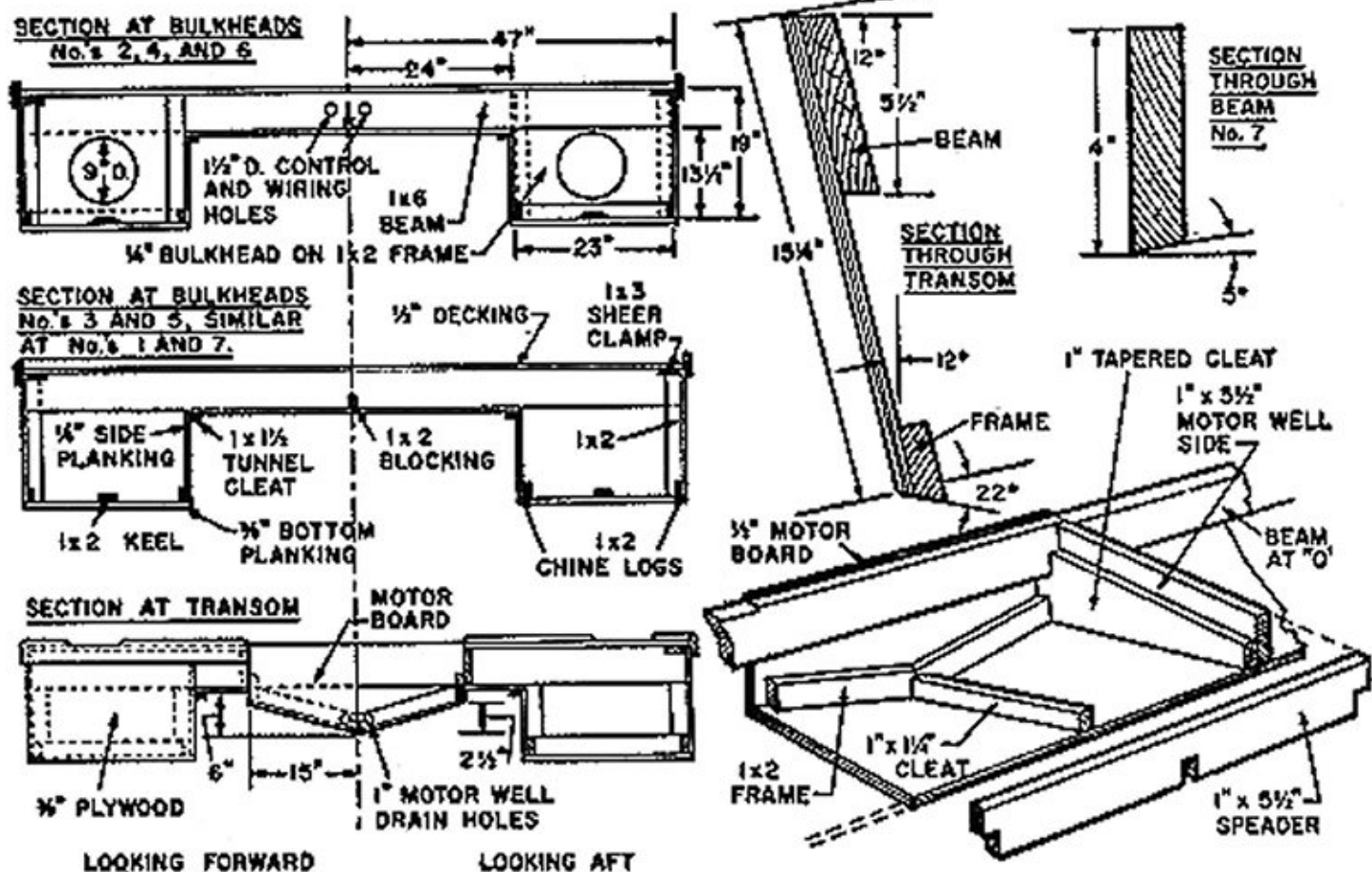

Note that two types of bulkheads may be used at bulkhead No. 4, depending on whether the side planking is a continuous 16-ft. panel (usually available only on special order) or two butt-joined, 8-ft. panels. If the planking is butt-joined, you'll have to make allowance in the bulkheads for the thickness of the $\frac{3}{8}$ -in. butt blocks that will mate to the side of the bulkhead and extend 8 in. on either side of the planking joint.

Beams. At stations 1, 3, 5 and 7, use 1 x 6 beams with uprights at their outer ex-

terminities in place of full bulkheads. Note that the beam at No. 7 must be trimmed and bevelled to mate with the $\frac{1}{4}$ -in. plywood tunnel planking.

The uprights at Nos. 1 and 7 may be left long for cutting to size later during assembly of the side planking, or may be left out temporarily and installed after the planking is in place.

Cut notches in the beams for the shear clamp and in the uprights for the chine log.

Transom. The transom is constructed in much the same way as the bulkheads. It's

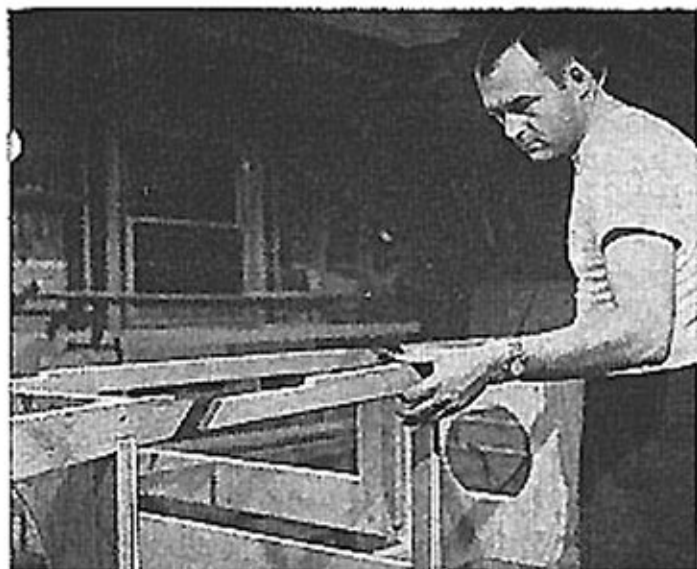

CHINE LOG JOINTS fall under joints in bottom planking and must be notched for $\frac{3}{8}$ -in. butt plates



STEM CURVE is a 4-ft. 6-in. radius which may be cut from 1 x 6 stock or laminated from $\frac{1}{2}$ -in. plywood

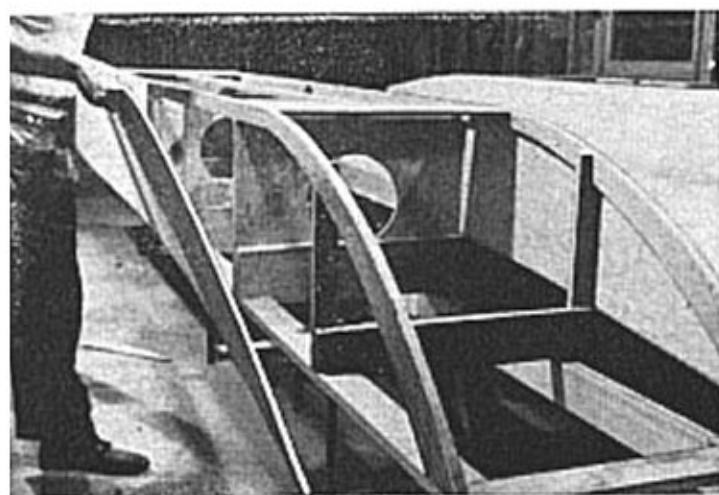

ALL FOUR PIECES of side planking have the same curve, so after one is laid out it can be used as pattern

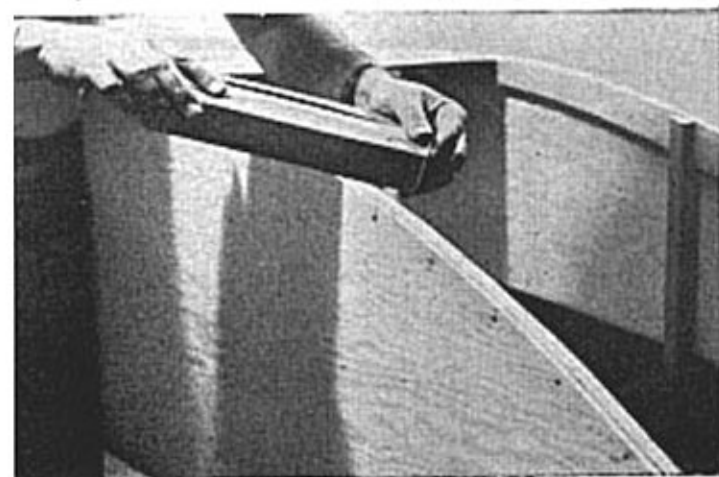

AFTER MOUNTING the side planking, sand the edges flush with framing so bottom planking mates tightly

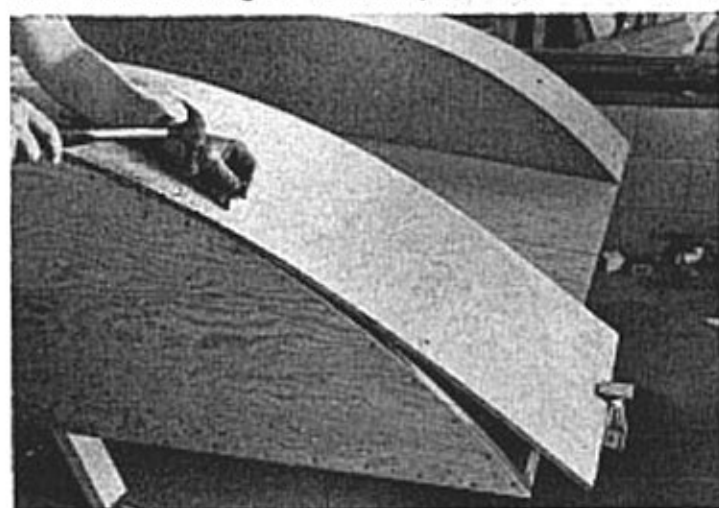

WHEN NAILING forward section of bottom planking, begin at aft end and work down the curve of stem

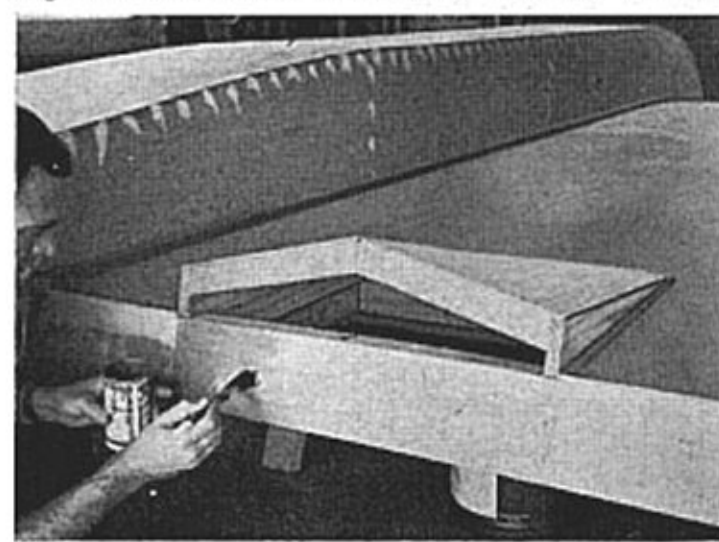

MOTOR BOARD cut from 1/2-in. plywood is mounted on the outside of transom frame and goes on last

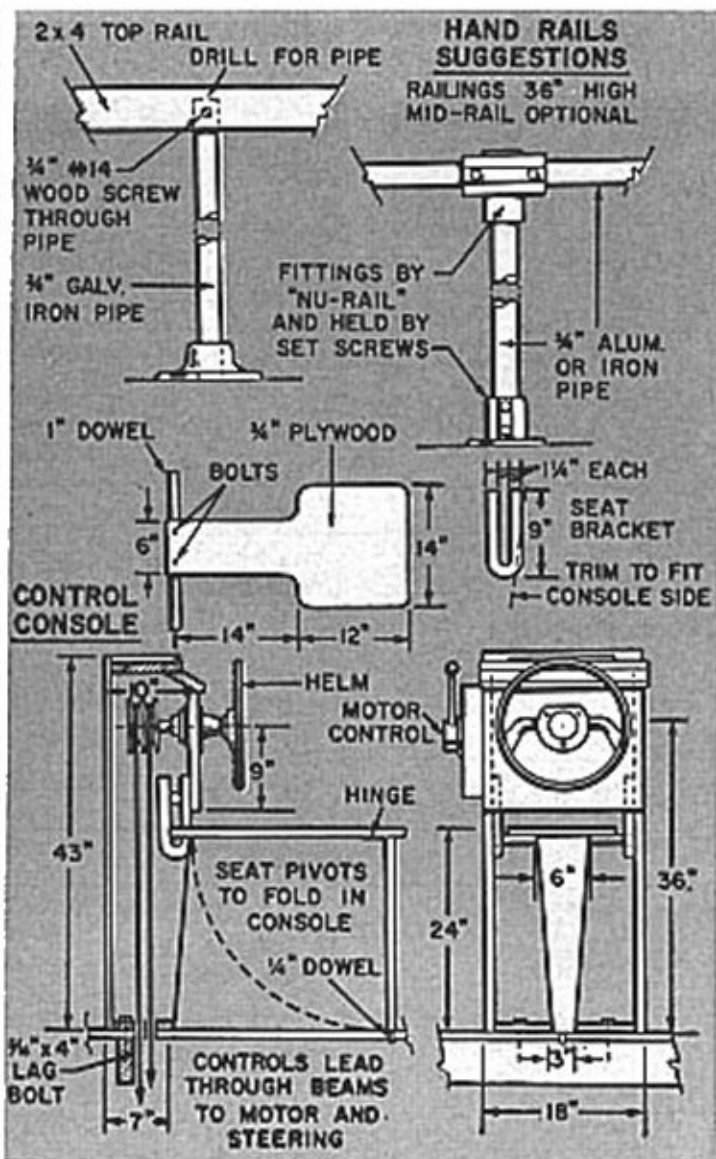

framed on the inside surface, with notches for the sheer clamp and chine log in the frame only and not extending through the plywood transom. Since the transom is set at an angle of 12°, the beam that connects the two bulkheads should be beveled 12° where it must mate with the tunnel and deck planking.

Building form. The hull is intended to be constructed bottom-side-up on a building form consisting of two 2 x 4 setup members spaced 5 ft. apart. These may be fastened directly to the floor or raised to a more convenient working level by mounting them on saw horses, as shown in the photos. In any case, they should be level lengthwise and athwartships, and held securely in position to prevent movement.

The bulkheads and beams are mounted on this form, spaced as shown and centered horizontally. The transom must be accurately spaced from the No. 2 frame on the hull center line and braced at an angle of 12°. The 1 x 3 bow piece should also be positioned on the form, as shown in the building-form drawing. Fasten all these framing members securely to the form and

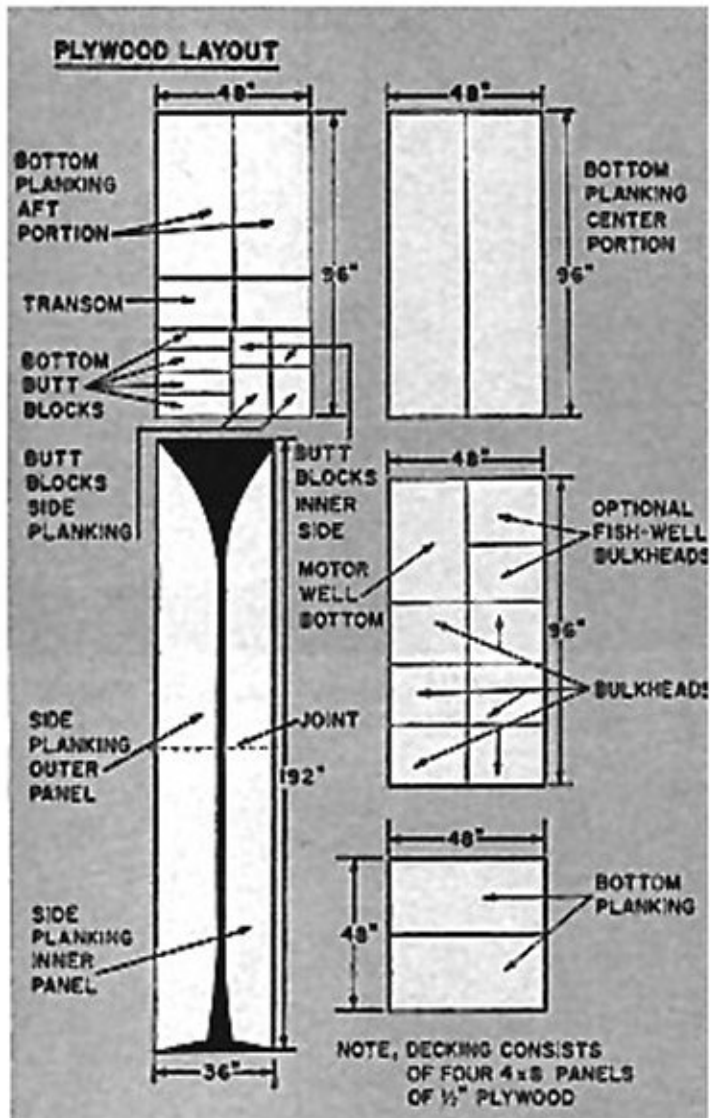

FIBERGLASS HULL before turning it over (Dynel was used here), then flip the hull and apply the decking

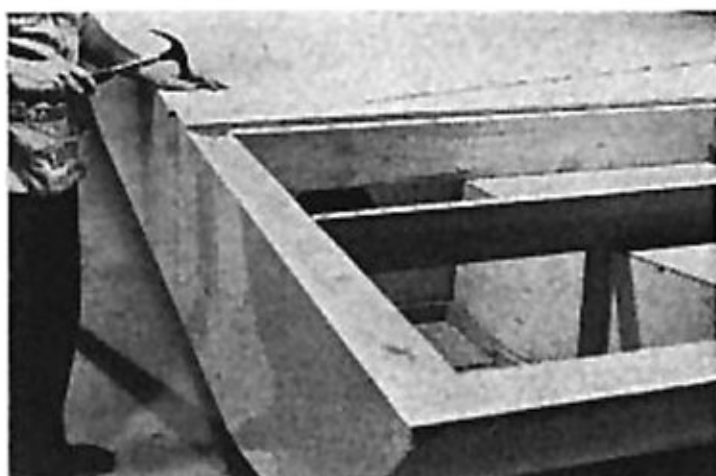

to one another to prevent movement during construction, since it's imperative that they remain vertical, accurately centered and properly spaced.

Avoid moving the form during construction. If you do so accidentally, however, retrue the structure before you continue.

Sheer clamps and stiffening. The 1 x 3 sheer clamps fit into notches at each of the beams and butt to the bow piece. Fasten with two 1½-in. No. 8 screws at each joint.

To stiffen the structure, notch a length of 1 x 2 vertically into the bottom of beams No. 1 through 7 along the center line. Secure it in place with 1½-in. No. 8 screws driven angularly into the beams.

Motor-well frame. In building the prototype, a width of 24 in. between longitudinals was used. While this is adequate for many small motors, the spacing was extended to 30 in. on the plans to accept larger motors and to provide more room for hooking up the steering and remote-control cables. The 1 x 6 longitudinals extend from the transom to beam No. 1, with 1 x 6 blocking on the beam acting as a spreader.

The motor well itself is in the shape of a V when viewed from the stern. Two cleats cut from 1-in. stock extend 1½ in. below the tunnel planking at the transom and must be tapered to be flush with the tunnel planking at No. 1. Fasten these cleats to the longitudinals with 1½-in. No. 8 screws.

The motor board can be cut from ½-in. plywood (not included in the materials list) or laminated from ¼-in. plywood. Add 1 x 2 blocking along the bottom edges for attaching the bottom planking, then mount the motor board on the beam and install the center bottom cleat which runs from the transom board to the beam at No. 1. Fair this framing but don't install the plywood planking until after the tunnel has been planked.

Tunnel planking. To provide a flush mating surface for the tunnel planking, bevel the bow piece and any beams which might require it. Two 4 x 8-ft. panels of ¼-in. plywood are used to plank the main part of the tunnel. The motor-well area is also planked with ¼-in. plywood, cut to fit. Coat the mating surfaces of the

(Please turn to page 220)

PM'S PLATFORM BOAT

(Continued from page 153)

frame with glue and fasten the planking in place by driving 1-in. nails 3 in. apart around the edges of the panels and 6 in. apart along the other framing members.

Side planking and chine logs. If you wish, the chine logs and stem may be pre-assembled to the inner and outer side planking before these pieces of plywood are secured to the frames. To do this, lay out the stem curve at one end and spring a batten between stations 0 and 2 to determine the curve at the stern end. Once you have laid out both curves on a side panel, use this as a template to cut the stern and bow members. Since the contours are identical, you may saw all of these at the same time.

Fasten the stem at the bow piece and uprights with 1½-in. No. 8 screws. Along the sheer, fasten the side planking with 1-in. nails spaced 3 in. apart. At the transom, use the same size nails spaced 2 in. apart. While you don't have to fasten the side planking at each bulkhead, it's desirable to secure the inside runner planking at bulkheads where it makes a junction with the tunnel planking.

Tunnel cleats. The 1 x 2 tunnel cleats cover the junction between the side and tunnel planking and are on the outside of the hull. If possible, fasten these from the inside, driving 1-in. nails from the underside of the tunnel planking and from the inside of the runner planking, spacing them 3 in. apart. Use 1½-in. No. 8 screws to attach to each beam.

Keel. The 1 x 2 keel is notched into the bulkheads and extends between the two butt blocks used to reinforce the joints in the bottom planking. Secure to each bulkhead with 1½-in. No. 8 screws.

Bottom planking. The entire bottom runner surface must be faired for the bottom planking. If the chine has been fitted to the side planking carefully, little, if any, fairing should be required along this area. The bow piece will have to be beveled to accommodate the bottom planking, however.

In the forward section, the grain of the ¾-in. plywood bottom planking runs athwartship, extending the width of a 4-ft. sheet to butt-join just forward of station No. 6 with the main bottom planking where the grain runs lengthwise. This 8-ft. main section of bottom planking runs aft to where it butt-joins with the stern portion of the planking. Make the butt blocks from ¾-in. plywood a minimum of 8 in. wide, fastening them with two rows of ¾-in. No. 8 screws spaced 2 in. apart on either side of the joint. Fasten

the bottom planking with 1¼-in. nails spaced 3 in. apart along the outer edges and 6 in. apart along the keel.

Motor-well area. The bottom of the motor well is made up of two pieces of ¼-in. plywood, one on either side of the centerline. Fasten these in place with 1-in. nails as you did the tunnel planking, after coating the frame surfaces liberally with glue.

At this point, the hull is ready to be turned right side up. To avoid turning the boat once again to finish it, however, take time out to sand and finish the bottom before you continue construction. (The prototype was covered with Dynel reinforced with resin, a process similar to fiberglassing but considerably easier because of the stretchable nature of the fabric. Complete instructions for applying Dynel or fiberglass may be obtained from the dealer from whom you purchase the material.)

Since the hull could be wracked at this stage, block it at bulkheads Nos. 2 and 6 and level it both lengthwise and athwartships. This makes sure it will remain level until the decking can be applied.

Decking. The decking consists of four panels of ½-in. plywood laid athwartships. Before installing it, fair all upper surfaces so it will lie flat on the framing and coat all mating areas with glue. Then fasten it in place with 1¼-in. nails spaced 4 in. apart along outer edges and 6 in. apart along inner framing members.

Before nailing the decking in place, however, decide where you wish to locate the control console and drill the necessary lead holes in the beams for steering and control cables. Also, any special storage ideas for utilizing space in the pontoons or wing deck should be considered at this time.

For instance, if you wish to locate fuel tanks and battery in the pontoons, it's easier to install plywood mounting plates and hold-down straps before the decking is in place. Hatches and provisions for ventilation can be taken care of afterward. The same goes for live bait or catch wells in the pontoons, or a rod storage rack in the wing deck. You might even consider filling this wing section with planks of Styrofoam, which would provide an extra 1000 lbs. of reserve buoyancy and make the fully loaded boat virtually unsinkable.

Bumper rail. The 1 x 3 bumper rail extends around the deck and projects 1 in. above the surface. Fasten it with 1½-in. No. 8 screws spaced 6 in. apart and countersunk so that they can be concealed with wood plugs.

Control console. Actually, the shape and location of the control console as de-

(Please turn to page 222)

PM'S PLATFORM BOAT

(Continued from page 220)

tailed here is entirely optional. Any shape console may be used and it could just as well be mounted almost anywhere along the center line of the boat. It's up to you.

As shown in the plan, the console features a swing-out seat with a folding leg. The seat is hinged to the leg, and the leg is equipped with a 1/4-in. dowel which fits into a hole drilled in the deck. Controls are mounted on the side, and control cables and steering lines are led beneath the deck back to the motor area.

Painting. If you fiberglass the deck, be sure to select paint compatible with the resin used. If you omit this, give the plywood a couple of coats of paint to hide the grain. Sand between coats and finish off with a good nonskid deck paint.

Incidentally, if the boat is to be left in the water, all interior surfaces should be coated with a rot preventative ("Cupri-nol" or similar) before the decking is applied. You may wish to consider this even though you plan to store the boat on a trailer during the season rather than leaving it in the water.

All areas to be left natural should be filled, stained and given three to five coats of good marine varnish, sanding between coats.

Fittings. Lights, cleats and other fittings are matters of personal taste, so long as they satisfy regulations in your area. As shown in the photograph at the beginning of this article, the prototype was outfitted with DIY aluminum railings assembled with NuRail fittings, and a canvas top stretched over aluminum bows. Such features are purely optional.

From the deck up, it's your baby! * * *

FASTENING SCHEDULE

| Item | Size | Type | Spacing or No. |
|--|--------------|--------|----------------|
| Frame to bulkheads | 1" | | |
| Beams to bulkheads and transom | 1" | Nails | 3" apart |
| Beams to uprights | 1 1/2" No. 8 | Nails | 3" apart |
| Side planking to chine logs and stems | 1" | Screws | 2 ea. joint |
| Chine logs to bulkhead and transom frame | 1 1/2" No. 8 | Nails | 2" apart |
| Sheer clamp to beams | 1 1/2" No. 8 | Screws | 1 ea. |
| Bow piece to stem | 1 1/2" No. 8 | Screws | 1 ea. joint |
| Keel to bulkheads | 1 1/2" No. 8 | Screws | 2 ea. joint |
| Tunnel vertical blocking to beams | 1 1/2" No. 8 | Screws | 1 ea. joint |
| Side planking to sheer | 1" | Screws | 1 ea. joint |
| Bottom planking at outer edges | 1 1/4" | Nails | 3" apart |
| Bottom planking along keel | 1 1/4" | Nails | 3" apart |
| Tunnel and side planking at tunnel cleat | 1" | Nails | 6" apart |
| Decking at outer edges | 1 1/4" | Nails | 3" apart |
| Decking at inner edges | 1 1/4" | Nails | 4" apart |
| Bumper rail to hull | 1 1/2" No. 8 | Screws | 6" apart |

MATERIALS LIST

| LUMBER No. Req'd. | Size* | Use |
|-------------------|---------------|--|
| 4 | 1 x 6-4' | Stem |
| 2 | 1 x 2-8' | Keel |
| 4 | 1 x 2-10' | Chine log |
| 4 | 1 x 3-4' | Sawn chine from Nos. 0 to 2 |
| 2 | 1 x 3-16' | Sheer clamp |
| 2 | 1 x 1 1/2-16' | Tunnel cleat |
| 1 | 1 x 2-12' | Vertical blocking for tunnel |
| 4 | 1 x 6-8' | Athwartship beams (Nos. 1, 3, 5, 7) |
| 3 | 2 x 6-8' | Bulkhead beams (Nos. 2, 4, 6) |
| 1 | 1 x 3-8' | Bow piece |
| 1 | 2 x 8-8' | Transom beam (thickness may vary with motor) |
| 3 | 1 x 3-16' | Bumper rail |
| 8 | 1 x 2-19' | Side uprights (Nos. 1, 3, 5, 7) |
| 3 | 1 x 2-12' | Bulkhead frames |

All sizes above are nominal, or "lumberyard size," rather than actual size. Dimensions allow for cutting to length.

PLYWOOD

| | | |
|---|-----------------|--------------------------------------|
| 2 | 1/4" x 3' x 16' | Side planking |
| 1 | 3/8" x 4' x 8' | Bottom planking (center portion) |
| 1 | 3/8" x 4' x 8' | Bottom planking (forward portion) |
| 1 | 3/8" x 4' x 8' | Bottom planking (aft portion, misc.) |
| 2 | 1/4" x 4' x 8' | Tunnel planking |
| 1 | 1/4" x 4' x 8' | Bulkheads |
| 4 | 1/2" x 4' x 8' | Deck |

FASTENINGS

Nails: annular-thread, bronze or Monel
 3 1/2 lbs. 1" No. 12
 2 1/2 lbs. 1 1/4" No. 12
 FH Screws: hot-dipped, galvanized or bronze
 1 gross 1 1/2" No. 8

GLUE

Plastic resin (5 lbs.) or resorcinol (1 gal.)



ON THE PROTOTYPE, the rails and top bows were made from aluminum assembled with NuRail fittings

2x4 TOP RAIL
 DRILL FOR PIPE

3/4" #14
 WOOD SCREW
 THROUGH
 PIPE

3/4" GALV.
 IRON PIPE

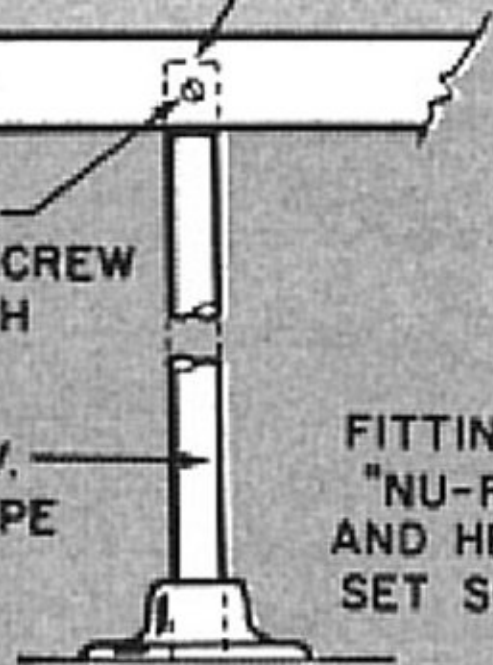

HAND RAILS SUGGESTIONS

RAILINGS 36" HIGH
 MID-RAIL OPTIONAL

FITTINGS BY
 "NU-RAIL"
 AND HELD BY
 SET SCREWS

3/4" ALUM.
 OR IRON
 PIPE

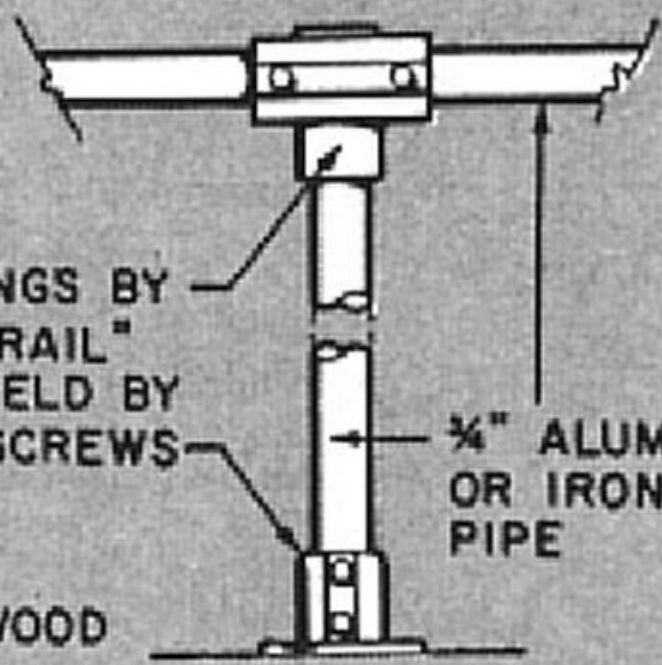

1" DOWEL

3/4" PLYWOOD

BOLTS

6"

14"

CONTROL CONSOLE

14" 12"

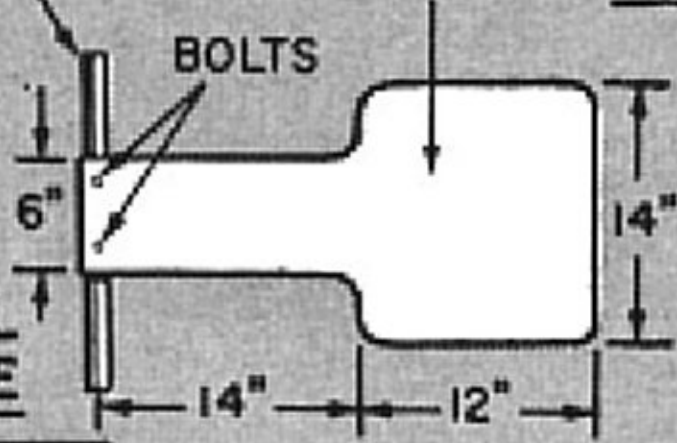

1 1/4" EACH

SEAT
 BRACKET

9"

TRIM TO FIT
 CONSOLE SIDE

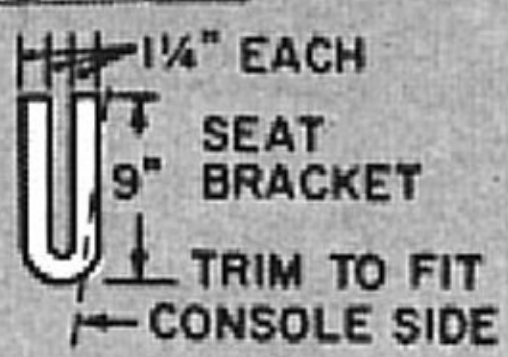

HELM
 MOTOR
 CONTROL

HINGE

SEAT PIVOTS
 TO FOLD IN
 CONSOLE

1/4" DOWEL

CONTROLS LEAD
 THROUGH BEAMS
 TO MOTOR AND
 STEERING

43"

9"

24"

36"

6"

3/4" x 4"
 LAG
 BOLT

7"

3"

18"

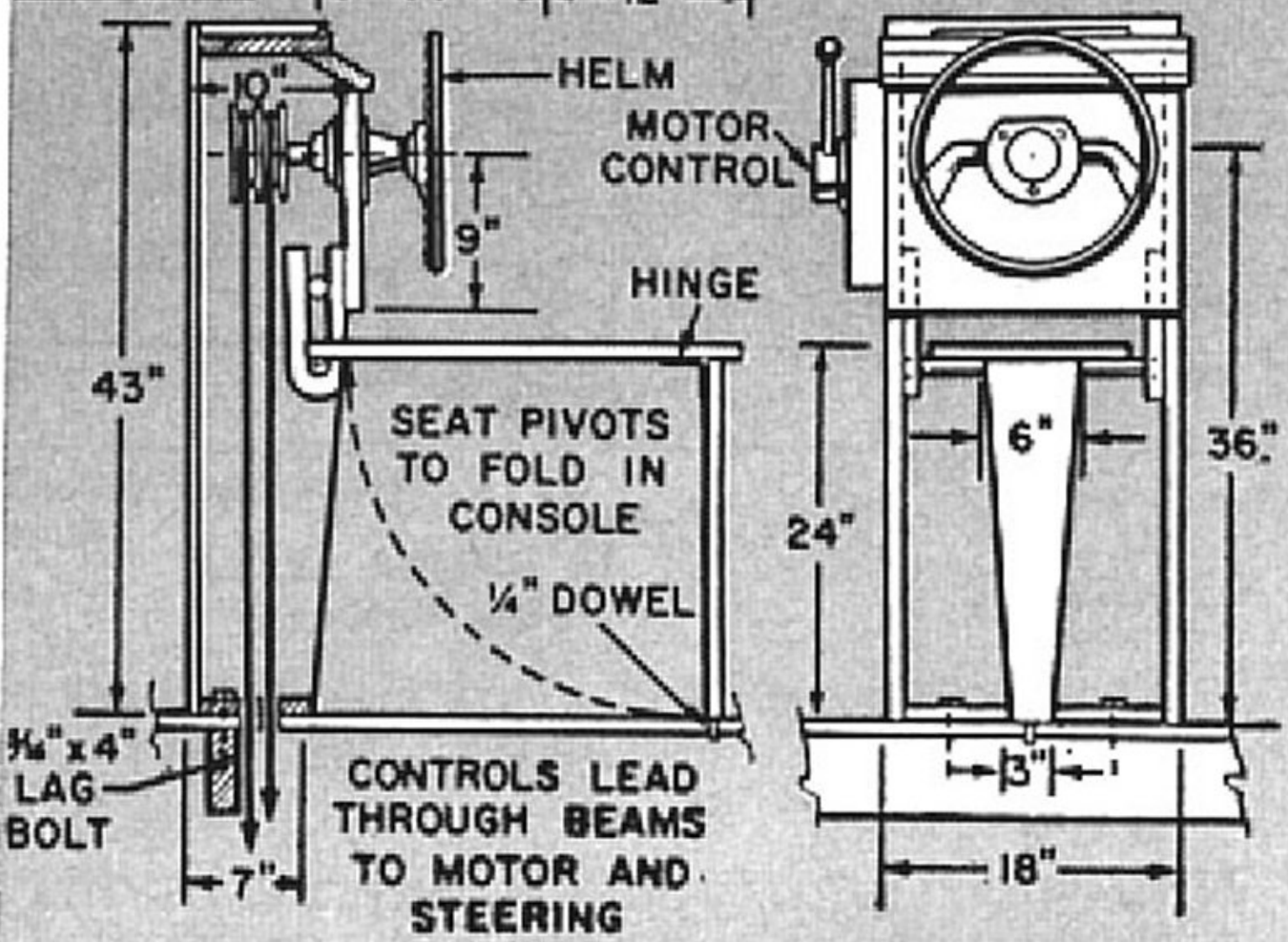

PLYWOOD LAYOUT

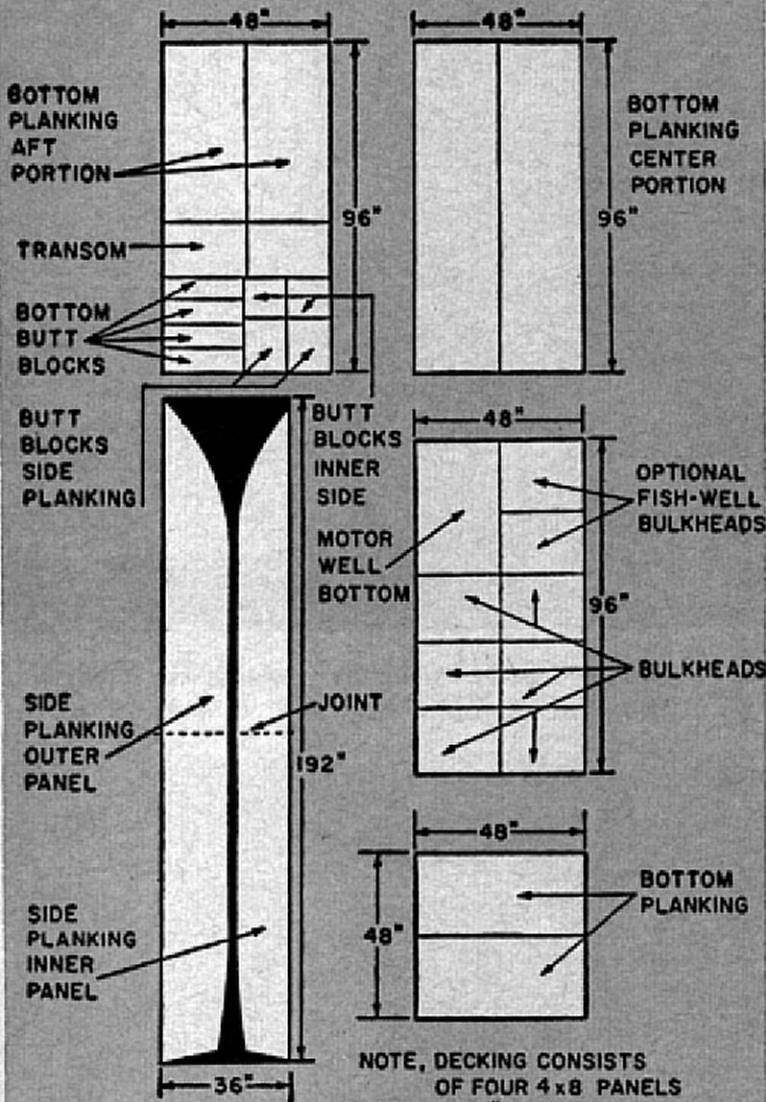

NOTE, DECKING CONSISTS OF FOUR 4x8 PANELS OF 1/2" PLYWOOD