

Hull of Can't Sink normally floats high and dry (Fig. 1). If the hull becomes swamped, however (Fig. 2), air chambers built into each seat keep it afloat.



# Can't Sink



9½ ft., fiber-glass dinghy

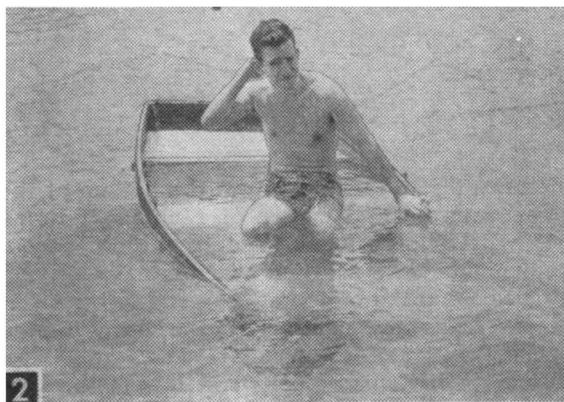

## STATEMENT OF USES

**USES:** Sturdy, lightweight dinghy for fishing, or for load or passenger carrying.

**LENGTH:** 9½ ft.

**BEAM:** 47 in.

**WEIGHT:** 85 lbs.

**CAPACITY:** 3 adults.

**CONSTRUCTION:** Fiber-glass hull over wooden framework; two mold frames required.

**H**ERE'S the sturdy, lightweight, fishing dinghy you've been looking for. Frame is encased in fiber glass, thus making each frame member a rectangular beam, and the color goes all the way through so you'll have no hull painting problems. Between the hull's interior and exterior layers of fiber glass is a layer of ¼-in. fiber-glass mat, the whole bonded together with polyester resin to give you a sturdy, leak-proof, lightweight boat. For safety's sake, air chambers built into each seat give approximately 3000 cu. in. of air space within the hull.

To start construction, first lay out the stem and the transom (Fig. 4) on ¾-in. exterior fir plywood. Cut the bevel on both pieces as you cut them to size. If you use a power handsaw, tack a guide strip along the cutting mark to aid you in making a perfectly straight cut. Cut the notch for the keel by making a series of saw kerfs and removing the remainder with a chisel.

Next, cut the framework for the transom and stem from 1x2 fir strips (except for bottom frame pieces on stem which should be cut from 1x3). Nail and glue the pieces to the transom and stem as shown in Fig. 4, extending the

framework far enough over the edges to allow for planing a bevel to conform to the bevel on the stem and transom. Notch the frame for the keel and lay out the notches for chines and clamps on the stem and transom. (Angles of the cuts are parallel to the bevels). Next, lay out a full-size pattern for the mold frames as shown in Fig. 4. Cut the pieces for the mold frames from 1x2, using any straight material you have on hand.

Cut gussets for mold frames from ¼-in. fir plywood, lay mold frame pieces in place on pattern and nail gussets in place using shingle or sheet rock nails. Now cut notches for chine, clamp and keel.

**The Building Form.** Mark off 8 ft. 5 in. on a new or used 10 ft. 2x10, then lay out the angle for the stem and transom (see Fig. 3),

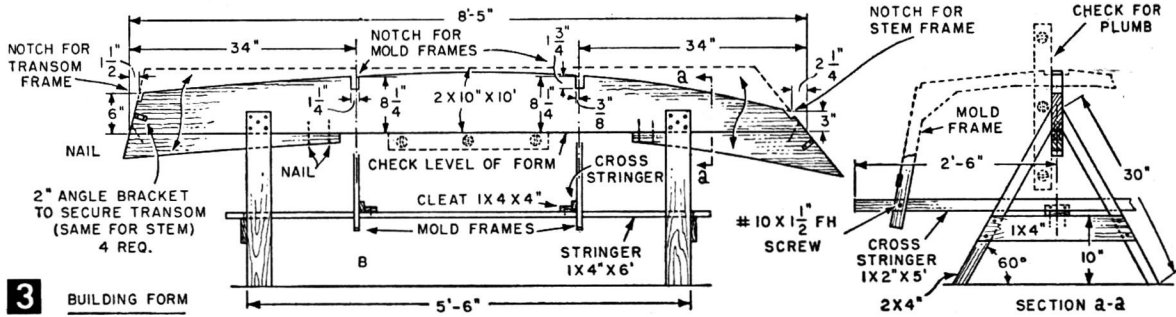

**3** BUILDING FORM

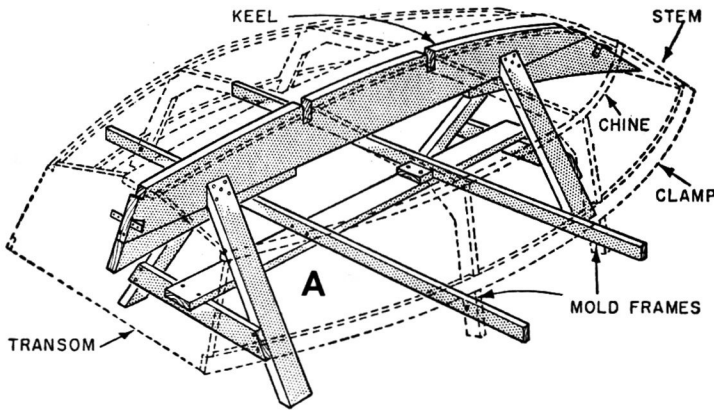

measure the distance up from the bottom at the stem, transom and center of each mold frame notch, drive a 6d finishing nail in at each of these points and spring a batten over the nails, driving a nail behind the batten at each end to hold it in place. Mark the contour of the form with a pencil.

Remove batten and nails and saw to the line, angle cuts first, then the contour cut. Make cuts square to face of form. Fasten 2x4 legs to form centerpiece with 6d common nails and stand the form in the location you intend to work in and check it for levelness and plumb as shown in Fig. 3. Check at both ends and shim accordingly. Recheck for level lengthwise and nail shims in place. Now, secure 1x4 cross members in place with 6d nails and then cut the notches for the two mold frames. Also cut the notches to clear the frames on the stem and transom. Cut notches wider than needed to allow for shimming or wedging frames securely in the form. When the hull is completed, wedges can be knocked out or hull easily lifted from form. Now cut the waste piece from the form's centerpiece in two and nail the pieces to the underside of the centerpiece as shown in Fig. 3.

Scribe a center line at the center of each mold notch on the form, center the mold frames in the notches and wedge them in place. (Cedar shingles make excellent wedges). Put a wedge in from each side for best results. Check the frames for squareness to the form.

Bevel the keel notch in the mold frames to conform to the contour of the form. The bottom of each mold frame should be  $\frac{1}{8}$  in. below the keel. (Remember, you are building the boat bottom up.) This  $\frac{1}{8}$  in. allows the Masonite to set

flush with the keel (see Fig. 6).

The next step is to fasten the mold frames securely to the form. To do this, lay a 5 ft. 1x2 cross stringer on edge on top of the 1x4 horizontal stringer, Fig. 3. Clamp this cross stringer to the side members of the mold frames and nail it to the horizontal stringer with a cleat as shown. Next, measure the vertical distance from the chine notches on the mold frames to the top of the cross stringer. Adjust the mold frames in the form notches until all side member chine notches are the same distance up from the cross stringer. Secure the mold frame side members to the cross stringer with a #10x1 $\frac{1}{2}$ -in. fh wood screw.

Now, position the transom and the stem and secure in place temporarily with #10x2-in. fh screws. A 1x2 tacked between the transom and the form and a 1x2 tacked between stem and form will help keep these frame members square to the form. If the bevel of the keel notch does not conform to the contour of the form, fair it in with a chisel or a block plane.

For additional support, fasten the stem and transom to the form with 2-in. angle irons, one on each side. The bottom of the keel must be flush with the beveled edge of the transom and the stem.

Clamp the keel in place and drill and countersink for #10x2-in. fh screws, four screws at each end. Remove keel, coat the joints with *Weldwood* glue, clamp in place, and screwfasten. Saw off the ends and plane flush with the stem and transom. (The mold frames are not secured to the keel; they are left free so that they can be removed later.)

Now fit the  $\frac{3}{4}$ -in. quarter-round chine in place, flush with the side and bottom bevels of the stem and transom and extending  $\frac{1}{8}$  in. above the side and bottom members of the mold frames. Secure at the transom and stem with glue and two #8 x2-in. fh screws, at the mold frames with a 4d finishing nail at each notch. (Either cut off these nails or pull them through the chine when mold frames are removed.) When chines are secured in place, saw off their ends and plane flush with the transom and stem.

Next, fit the clamps in place and secure their ends to the transom and stem with glue and

two #10x2-in. fh screws. Saw the ends off and plane flush with transom and stem. Screwfasten the mold frames to the clamps from the inside with one #10x2-in. fh wood screw at each joint and cut and fit the center seat bracket (Fig. 6). Secure in place with glue and one #8x1¼-in. fh screw at the clamp and glue and one #8x1½-in. fh screw at the chine. Seat bracket is flush with the outside surface of the chine and clamp and ⅛ in. below the bottom edge of the chine.

Fasten the ¼x¼-in. soft-wood, temporary molding battens to the chine clamp, keel, transom, stem and seat brackets with ½-in. brads (see Fig. 5). Each length of these battens should be roughly 3 ft. long. Position them by gaging a ⅛-in. guide line indentation on all surfaces to which they are to be secured, then push in the ½-in. brads, spaced 6 in. apart, with a pair of pliers. Use a piece of scrap ⅛-in. Masonite to check your work. When installed, the Masonite must be flush with the framework.

Now lay a sheet of ⅛-in. Masonite, smooth side out, on one side of the frame so that it overlaps the keel about ¼ in. on the center. Temporarily tack it in place for marking along the inside of the keel, chine, stem and transom, remove and cut to the line with a fine-tooth cross-cut saw. Mark and cut the opposite side in the same manner. The sides are made up of three pieces: the two ends and the piece that fits between the seat brackets (see Fig. 9).

To cut the ⅛-in. fiber-glass mat to shape, lay it on a clean flat surface, lay the Masonite pieces on top of the mat and mark around them with a soft black pencil. Cut out the pieces and set them aside until needed. (Key them to correspond with Masonite sections.)

Now, apply a bonding coat of resin, clear or colored, to the exterior surface of the framework. Don't let the resin run down on the ¼-in. molding. While this bonding coat is curing apply three heavy coats of mold release wax to the smooth surface of the Masonite, place Masonite back on the hull frame and secure it in place with ¼-in. brads. Use a minimum number of brads.

**Applying the Fiber-Glass Cloth.** You'll need scissors, a 2-in. paint brush (cheap quality), a 7-in. red rubber squeegee, a mohair roller, a sharp knife or hacksaw, and #3 sandpaper (production). Apply the fiber-glass cloth in steps: 1) one side and bottom; 2) opposite side and bottom; 3) transom and stem. Here are a few tips:

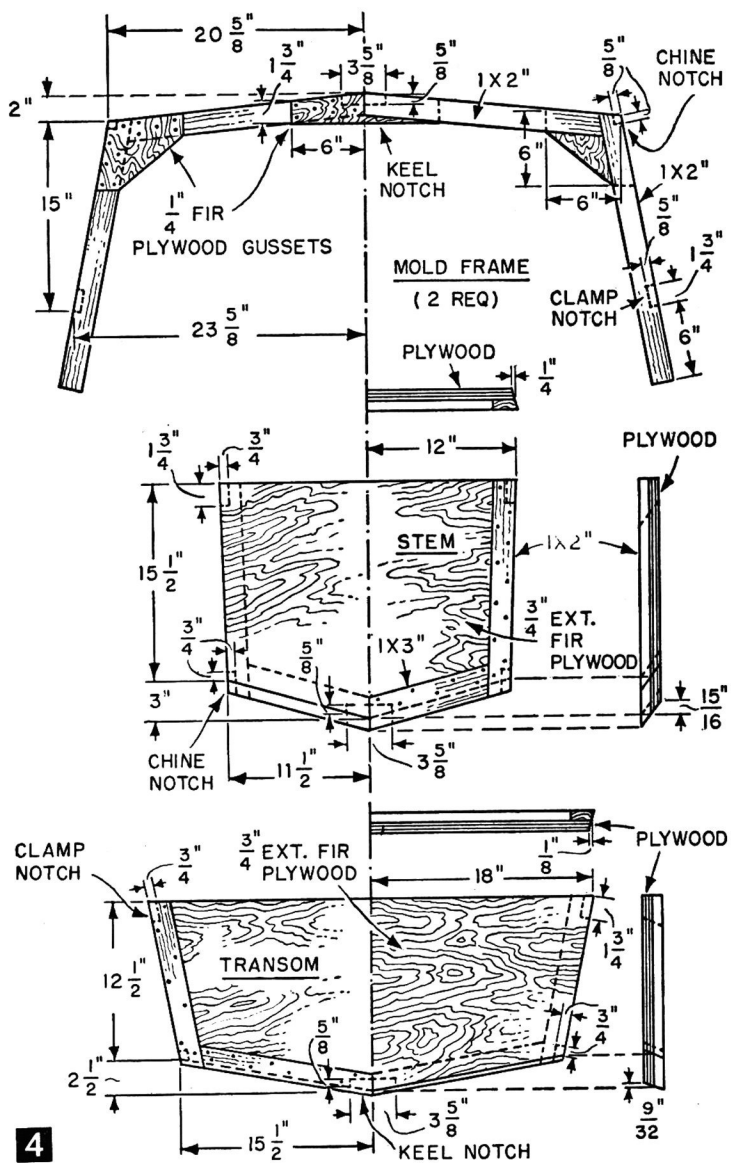

Wash your brush, roller, and squeegee after using. To clean a brush, pour ¼-in. of Lux detergent in a Dixie cup, dip the brush in the cup and work the detergent well into the bristles. Then wash the brush in warm running water. A rectangular aluminum foil pan can be used as a container in which to clean the roller. Roll detergent well into the mohair bristles before washing in warm running water.

If you are working outdoors you must be in the shade and the temperature should be at least 70°. Mix only 1 qt. of resin at a time and be sure to stir the hardener in thoroughly. Portions of resin can be mixed at a time; see instructions on the container. Store remainder in clean glass jar.

Don't work in the sun or when humidity is high. Don't let resin come in contact with your clothes.

To apply the fiber-glass cloth, drape it over the hull so that one edge overlaps the clamp by ½-in. at the center of the hull. The opposite

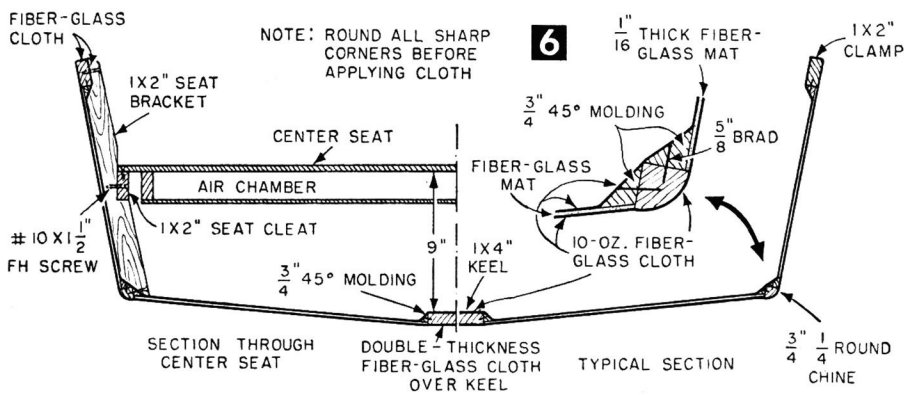
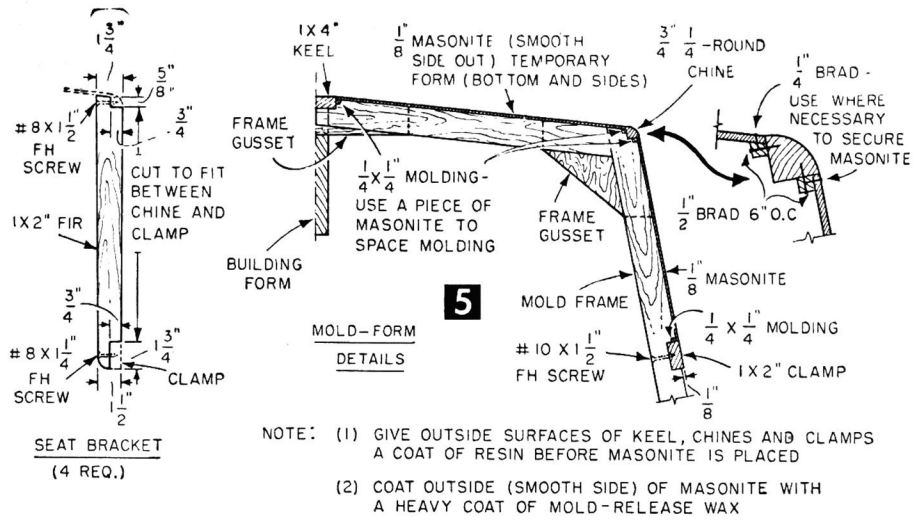

edge will overlap the keel. Smooth out the cloth the full length of the hull and down diagonally over the stem and the transom. The cloth will take a circular shape over the bottom of the hull as you smooth it out to conform to the sides. It is possible to shape the cloth with your hands to the hull without slitting at the corners of the transom and stem. Cut the cloth to length after you have shaped it to the hull. Allow at least 1 in. of overlap at the stem and transom (see Fig. 7). Secure cloth in place with a few thumb tacks to keep it from shifting. Masking tape can also be used except on the waxed Masonite. Remove tacks as you apply the resin.

Mix up 1 qt. of resin, with color added, and

start applying the resin by pouring a small amount on the bottom of the hull either at the stem or the transom. Proceed to roll the resin into the cloth with a mohair roller. Roll a section on the bottom and then down over the stem. Be sure to apply enough pressure to force the resin through the cloth so that it will bond with the bonding coat of resin on the stem, transom, keel, chines and clamps. Apply enough resin to completely saturate the cloth. If pinholes develop, go over the surface with the squeegee and force out the air that causes the pinholes.

Reroll surfaces you squeegee. The simplest way to apply resin to the sides is to hold the roller up against the clamp and pour a small amount of resin between it and the side, then roll up towards the chine. The final rolling of the side should be downward toward the clamp, pulling the cloth tight over the chine.

If wrinkles should develop they can readily be worked out with your hands as you go along from stem to stern. Check to be sure that the cloth is bonding to the stem, transom, chine, clamp, keel and seat brackets before you clean up your tools.

Curing time will depend upon weather conditions. The drier the air, the faster the curing. Resin should become tack free in about three hours under normal conditions.

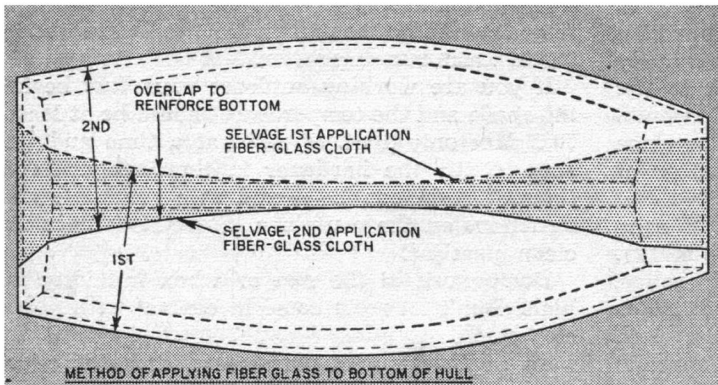

Feather the edges of the cloth with #3 production paper and apply other section of cloth to the opposite side of the hull. Let cure, feather-edge—a disc sander does a good job—and apply fiber glass to the stem and transom, cutting the cloth to overlap the sides and bottom (see Fig. 7).

Trim the excess cloth off with a sharp knife or hacksaw, applying the cutting pressure toward the hull to prevent breaking the bond between the hull and the cloth. Feather all overlapping edges to completely smooth out the hull and

check for pinholes. Patch pinholes by sanding lightly and filling with a mixture of resin and sanding dust particles. Mix the dust and resin to a creamy paste.

When the pinholes have been patched, lightly sand the entire hull. Then brush and wipe off the sanding dust and apply a second coat of resin with a mohair roller. Let cure, again inspect for and patch pinholes, and sand the entire hull again to remove any runs or high spots. Brush and dust before applying the final coat of resin. When the final coat has cured, the surface will be as smooth and slick as glass.

Remove the hull from the form by first removing the shingle wedges, then the angle irons from the stem and transom and, finally, the mold frame side members from the cross stringer. Place the hull on a pair of saw horses and wedge it up to keep it from rocking. Cover the wedges with rubber to keep the hull from slipping off the horses.

Begin application of the  $\frac{1}{16}$ -in. fiber-glass mat which reinforces the bottom and sides by cutting the extensions of the mold frames flush with the clamps. Do not remove the mold frames. Next, remove the  $\frac{1}{4} \times \frac{1}{4}$ -in. temporary molding battens from the keel, transom, stem and chines on one side of the bottom only. Next, remove the Masonite, starting at one corner to release it from the fiber glass. When the end is loose enough to get your hand in between it and the fiber glass, insert a tapered stick and push it along to aid in releasing. Work from both ends toward the mold frames. Break the Masonite at the mold frames and remove it from between the mold frames. If any small patches of Masonite adhere to the fiber glass, shave them off with a sharp chisel.

Lay in the piece of  $\frac{1}{16}$ -in. fiber-glass mat (previously cut to fit), slipping it under the two mold frames. Saturate the mat with resin by holding it down with a 12-in. square of  $\frac{1}{4}$ -in. mesh hardware cloth, spreading the resin through this cloth with a brush. The hardware cloth prevents the brush from picking up the

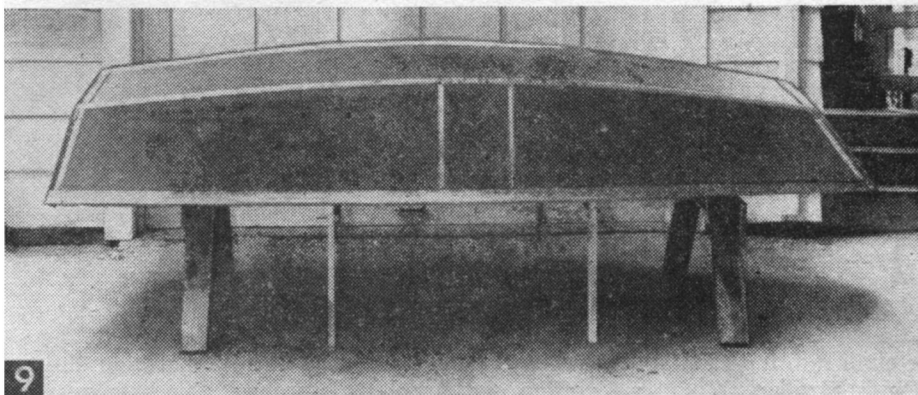
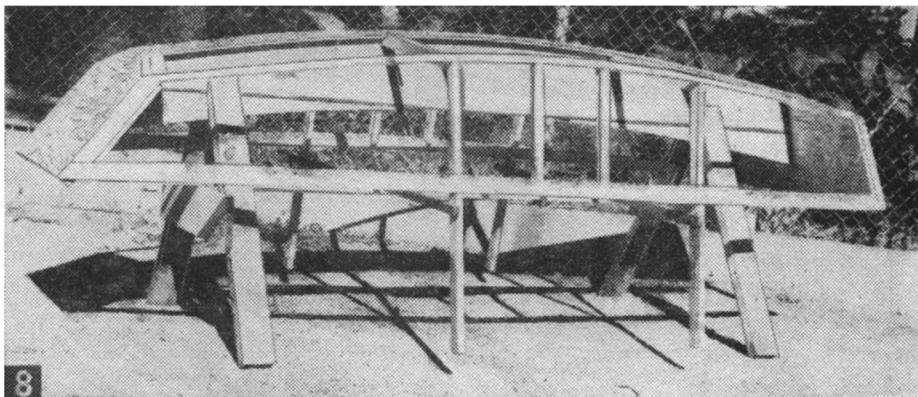

Completed framing (8); hull ready for fiberglassing (9). Masonite is removed after first coat of fiber glass has been applied.

loose fibers of the mat. Pour the resin in the center of the cloth and spread, moving the hardware cloth along as you go. Repeat the same operation for the opposite side of the bottom. Allow time to cure.

Prop the hull up on its side to prevent the mat from sagging and the resin from running when doing the sides. Allow the first side to cure before doing the opposite side.

Now remove the mold frames, and sandpaper the mat surface with #3 production paper.

The  $\frac{3}{4} \times \frac{3}{4}$ -in.  $\times 45^\circ$  molding at the keel, clamps and chines (see Fig. 6), reinforces the hull and also eliminates sharp corners so that the inside layer of fiber-glass cloth is easier to apply. Secure it in place with  $\frac{5}{8}$ -in. brads, spaced as necessary to hold it in place. Be extra careful when driving brads into the chine. It will be necessary to change the angle of the molding to something greater than  $90^\circ$  if it is to fit up tight between chine and sides and chine and bottom. A  $45^\circ$  molding is not required between the bottom and the stem and stern. When all molding has been installed, plane or sand edges that extend beyond the member it is secured to. A small model builder's plane, or one that uses a safety razor blade will do this job.

Apply the fiber glass cloth to the inside in sections: 1) the bottom; 2) the sides; 3) the stem and transom. Apply bottom covering in two pieces, one side at a time, cutting the cloth so it overlaps the keel and wide enough to cover the chine molding and lap up 1 in. on the stem

NOTE: IN EACH CASE, PAINT INTERIOR AND SET COVERS IN WET PAINT OR CAULKING COMPOUND  
USE WELDWOOD GLUE ON ALL JOINTS

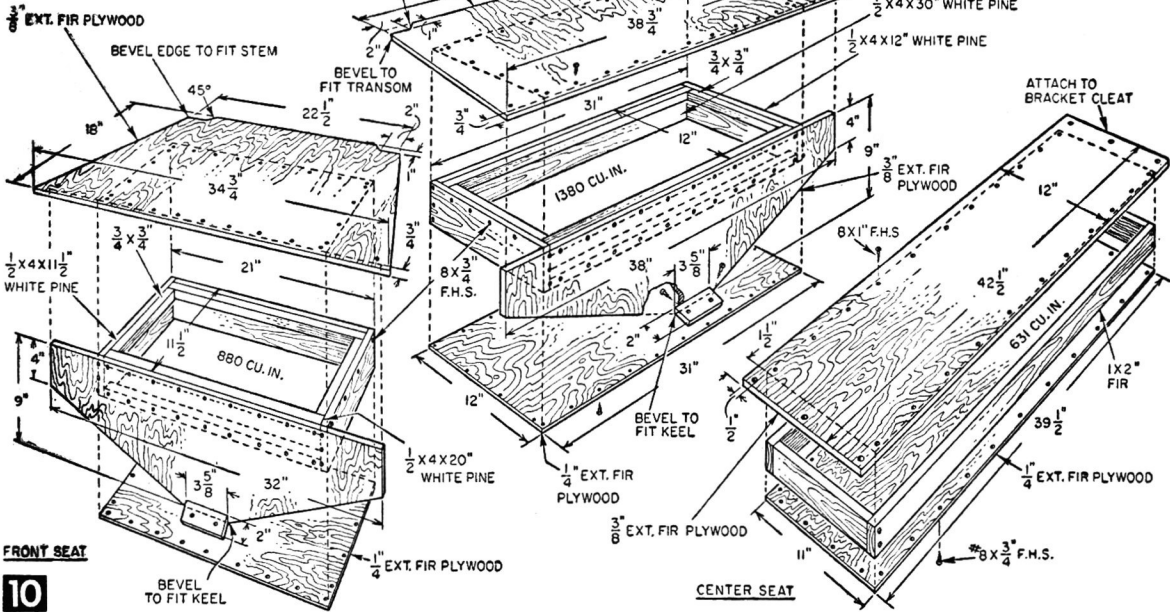

**FRONT SEAT**

**10**

and transom. Apply the resin with mohair roller and a brush. The brush comes in handy to shape the cloth into the tight spots that can't be gotten to with a roller. When one section of the bot-

tom inside covering has cured, do the other. Cloth is applied to the sides in three pieces: the section between the seat brackets and the two ends. Cut it to overlap the chine and wide

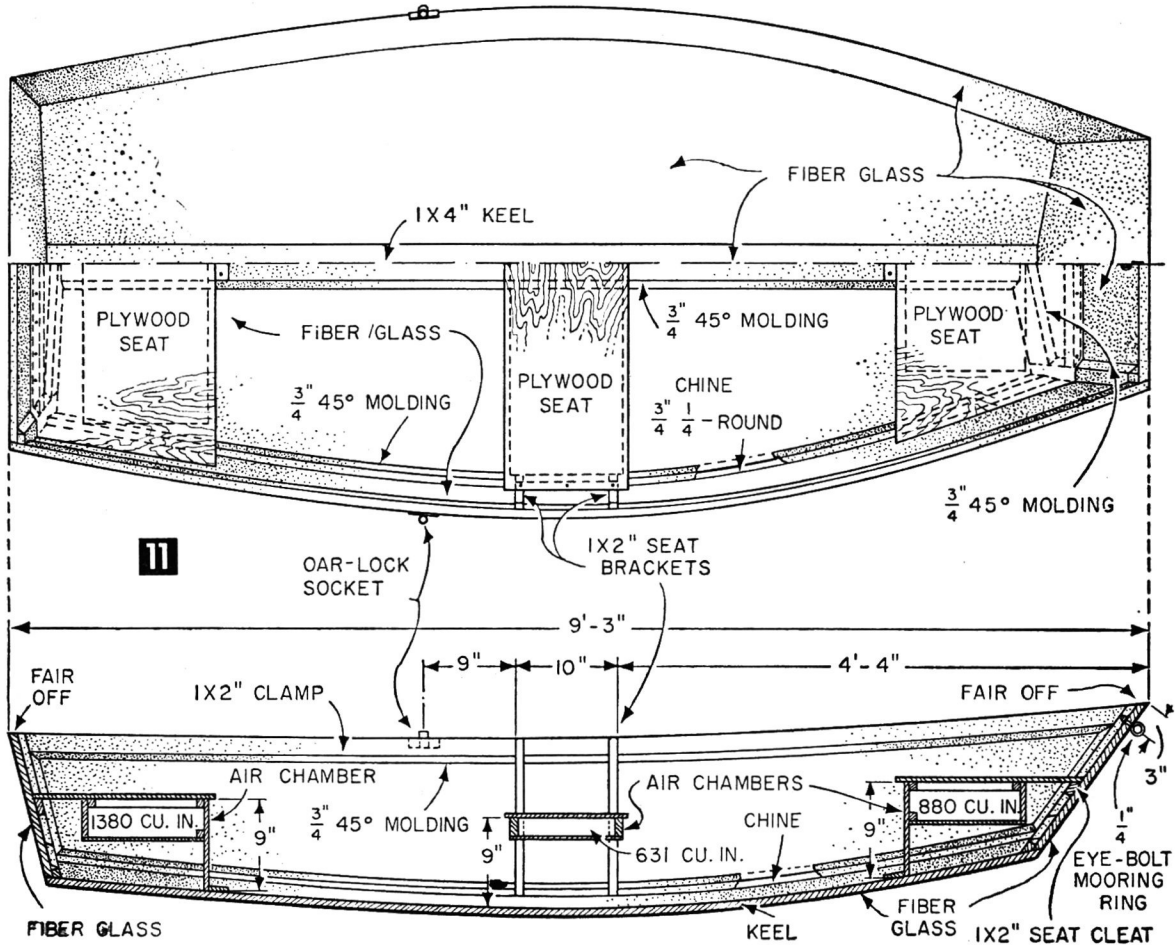

MATERIALS LIST—CAN'T SINK

No. Reqd.	Description	Use	No. Reqd.	Description	Use
1 pc.	3/4 x 18" x 5' exterior fir plywood	stem and transom	1 gr.	#8 x 1" fh screws, zinc coated	
1 pc.	1/4 x 24" x 3' exterior fir plywood	gussets and air chamber cover	1 gr.	#8-3/4" fh screws, zinc coated	
2 pcs.	1 x 4" x 10' fir or spruce	keel and stringer	3 doz.	#10-1 1/2" fh screws zinc coated	
8 pcs.	1 x 2 x 10' fir or spruce	mold frames, clamp, stem, and transom framing, center seat brackets and seat cleats	1 box	5/8" brads	
2 pcs.	3/4" x 10' quarter round molding, pine	chine molding	1 box	1/2" brads	
10 pcs.	3/4 x 3/4" x 10'-45° molding, pine	stem bottom frame form	1	1/4 x 1 1/2" eye bolt	mooring eye
1 pc.	3/4 x 3" x 4' fir or spruce	legs	4	2" angle irons 1/2" wide	stem and transom
1 pc.	2 x 10" x 10' fir (new or used)	sides and bottom	1 pr.	oar locks	oar locks
1 pc.	2" x 4" x 12' fir (new or used)	seats	8	#8 x 1 1/2" fh stove bolts	oar locks
2 pcs.	1/8" x 4 x 10' tempered Masonite	air chamber and seat stiffener	1 pc.	1/4" x 12 x 12 mesh hardware cloth	for seats
1 pc.	3/8" x 4 x 6' exterior fir plywood	seat corner strips	1 pt.	paint (Interlux)	
1 pc.	1/2 x 4" x 12' pine				
2 pcs.	3/4 x 3/4" x 8' pine				
100 ft.	1/4 x 1/4" molding new or cut from scrap material				

Fiber Glass\*

15 yds. 10 oz. fiber glass cloth 38" wide  
 15 qts. resin (color to suit—red, yellow, blue, green, black and white)  
 6 yds. 1/16" thick fiber glass mat 36" wide  
 \* Available from the Fiber Glass-Evercoat Co., 7218 Vine St., Cincinnati 16, Ohio, or Herters, Inc., Waseca, Minn.

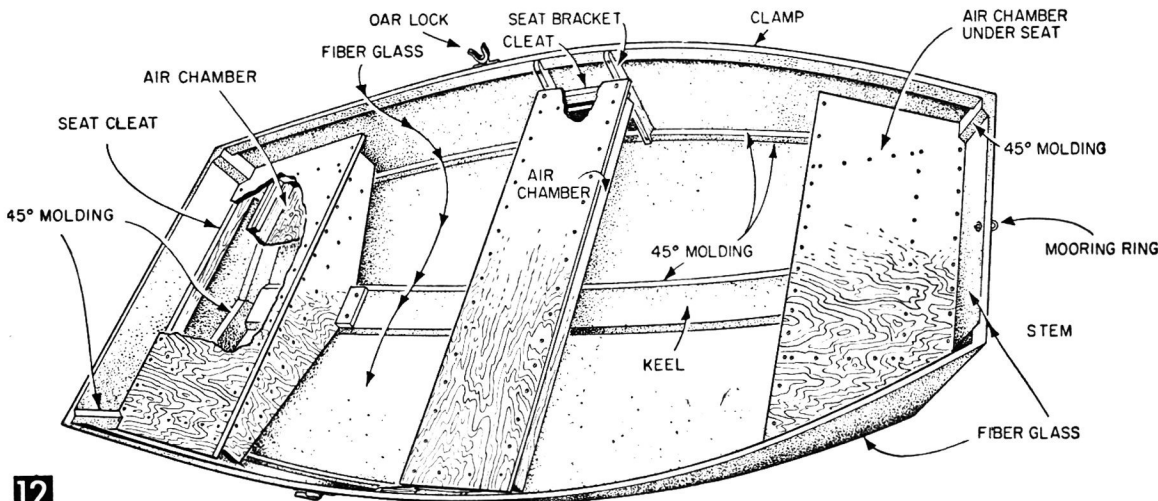

12

enough to completely enclose the clamp. At the ends the cloth should lap up on the stem and transom 1 in. Seat brackets can be covered with fiber-glass cloth at this time or painted later. Complete opposite side in the same manner, then the stem and transom. To cover top edge of clamp, trim outside and inside coats of fiber-glass flush with clamp, rounding edges slightly. Coat with resin, allow to dry to tackiness and apply cloth (scrap material 2 in. wide). Press cloth into resin with hands. Apply final coats after first coat has cured and been feather-edged.

Check the interior for and fill any pinholes that may exist and give the interior its second and final coat of resin. (The interior finish is left rough to prevent slippage under foot.)

While the last coat of resin is curing, make up the seats (Fig. 10). All joints are glued and screwed. Paint the interior of the air chambers, under each seat, to make them air tight. Covers should be seated in thick wet paint or calking compound. Paint the seats any color which contrasts with the color resin you have used.

Make up the seat cleats and secure in place with #10x1 1/4-in. fh screws (see Fig. 5). The front and rear seats are not fastened to the sides of the hull, but are secured to cleats on stem

and transom and to the keel. The center seat rests on cleats secured to the side seat brackets. Use #8x3/4-in. fh screws to secure seats to the cleats, #10x1 1/4-in. fh screws to secure to keel.

Drill a 1/4-in. dia. hole in the stem for the 1/4-in. mooring eye bolt (Fig. 11). Use a washer under the eye and nuts. Mount the oak locks as shown in Fig. 11 and your boat is completed.

Glove Compartments for Boats

• A lady's large discarded purse makes an ideal compartment for storing tools, fishing tackle, lunch, binoculars, camera and other items generally carried on a boating trip. Fasten the purse to the side of the boat, seat or transom with staples or screws.