

Let's try the "LITTLE CHIEF" CANOE



LITTLE CHIEF is a canoe with many virtues, ideally adapted to quick, easy construction.

Canoes are not easy to build, but here is one example of the red man's boat that can be made of ordinary materials for a fraction of the cost of conventional canoes. It has attractive molded lines and may be built either as a paddling model or, with slight changes, adapted for use with small outboard motors.

The first job is to collect the various materials needed. Then one can begin by drawing full size paper patterns of the mold frames and stems. To speed up the drawing task and insure symmetry, fold your paper lengthwise and draw one side. Transfer the outline—and when the paper is unfolded your pattern is complete.

The mold frame and stem material is laid upon the pattern outline, marked and cut to shape. Molds and stems are then notched for the keel. Next saw the form to shape and mount on a sawhorse at a convenient working height, then notch this form for the molds.

So you've always wanted your own canoe?
Here it is, ready for you to build.

Mount molds and stems atop the form and attach the $\frac{3}{4}$ " x $1\frac{1}{2}$ " keel. The keel is tapered at each end to fit the stems and screw fastened to stems and molds with 2" No. 8 flat head screws.

Before attaching the stringers, align the molds and stems and secure them temporarily by tacking a light batten in place on each side. The stringers, 12 in number,



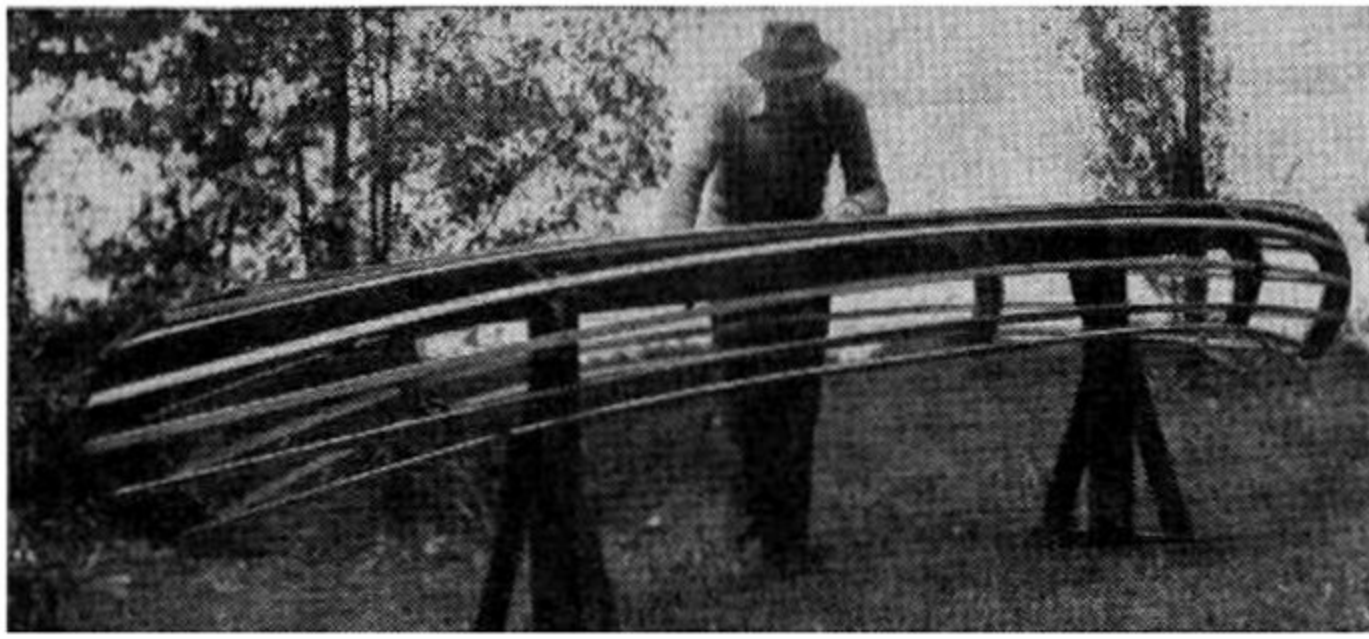

The author shows how he built the Little Chief on a work frame closely akin to a saw horse. As the photo at the right indicates, full size patterns come in very handy.



screw at each mold joint and one 1 1/4" No. 8 flat head screw at each stem joint.

If you intend to use an outboard motor with your canoe, provide extra No. 2 molds as indicated. To build the paddling model, continue as outlined above until all stringers are in place. To give a final graceful sweep toward the bow, 1/4" plywood fillets, shaped as indicated in the

are now attached to molds and stems, spaced equally between keel and sheer. One stringer will be directly above the keel, with six on each side. Bevel the stringer ends to fit the stems and fasten them with one 2" No. 8 flat head

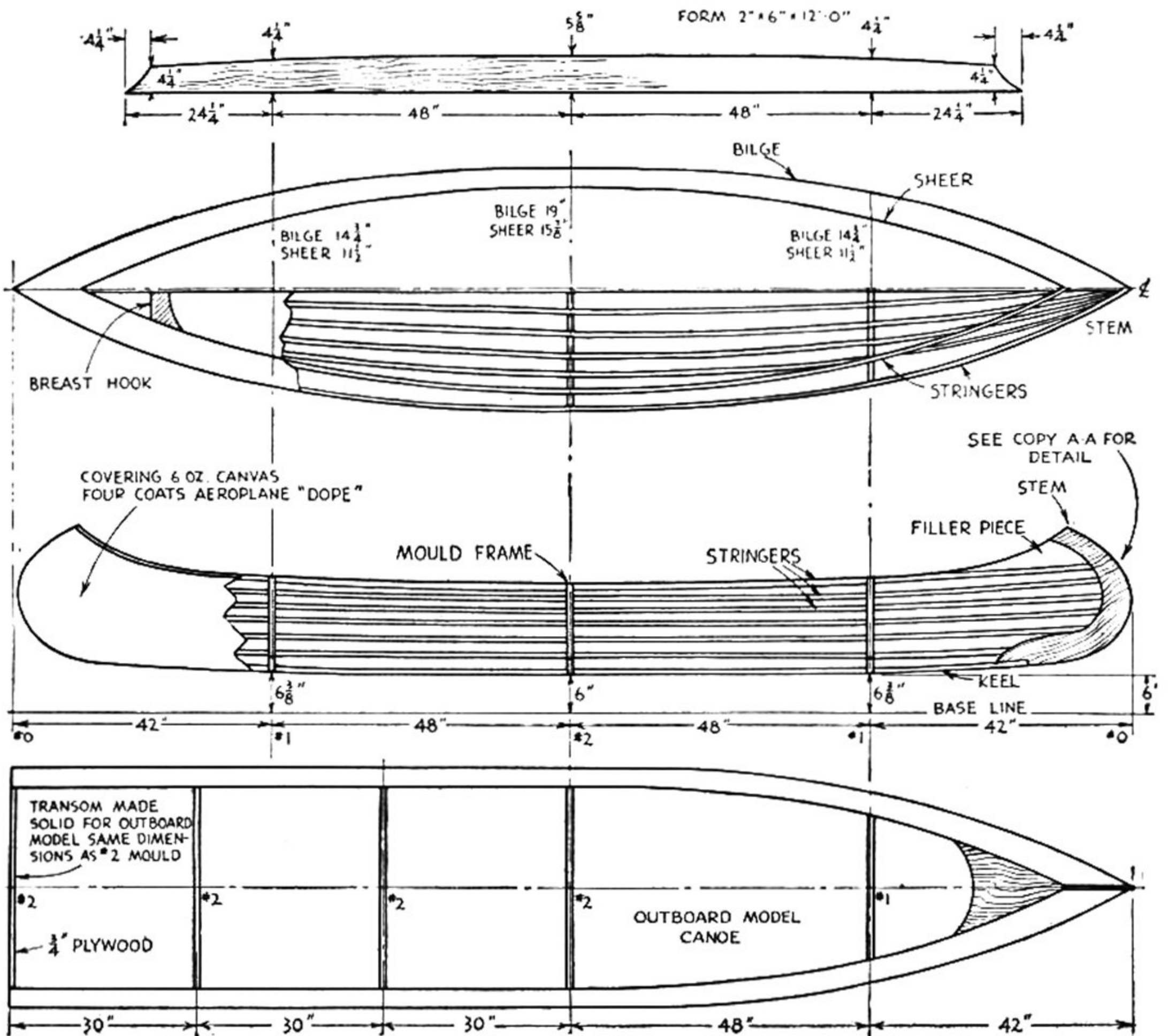

BILL OF MATERIALS

| | | |
|-----------------|---------------------------|-------------------------------|
| Stringers | 13 pcs. 1" x 1/2" x 16' | } Spruce, fir, hemlock, pine. |
| Keel | 1 pc. 3/4" x 1 1/2" x 12' | |
| Mouldings | 2 pcs. 1/4" x 3/4" x 16' | |
| Moulds & Stems | 1 pc. 3/4" x 4" x 4' | Fir plywood. |
| Floors, Fillers | 1 pc. 1/4" x 4" x 4' | Fir plywood. |
| Braces | 1 pc. 3/4" x 4" x 12' | Oak, ash, walnut. |

FASTENINGS AND MATERIALS

- 3 Dozen 1 1/4" No. 8 Flat Head Screws.
- 5 Dozen 2" No. 8 Flat Head Screws.
- 1/2 Pound 1/4" Tacks.
- 3 Gallons Ferdico's Wing Dope.
- Cloth for covering—10 yds. 36-in. width or 5 yds. 70-in. width six to eight ounce canvas or extra heavy muslin.
- 1 Pint Edwards Smith's Canoe Enamel.
- Other materials and parts as listed in article.

drawings, are mortised flush into the stringers forward and screw fastened to the stem and top of sheer stringers.

At this point it is wise to give the entire framework a coat of equal parts linseed oil and turpentine for preservation.

To cover properly, leave the framework on the form and prepare the cloth covering, which may be either a single layer of 6 or 8 oz. duck or heavy muslin doubled on the bottom.

This cloth may be applied in a single width or with a seam tacked along the keel. In either case, stretch the cloth in place snugly without wrinkles and tack it along the keel, sheer and stem with 1/4" tacks spaced about one inch part. Apply four coats of Ferdico's wing dope to the cloth, allowing a drying interval of at least one half hour between coats and sanding each coat lightly before applying the next. Finish by applying two coats of Edward Smith's Canoe Enamel of any desired color. This gives a gleaming and a durable finish.

COVERING 6 OZ. CANVAS

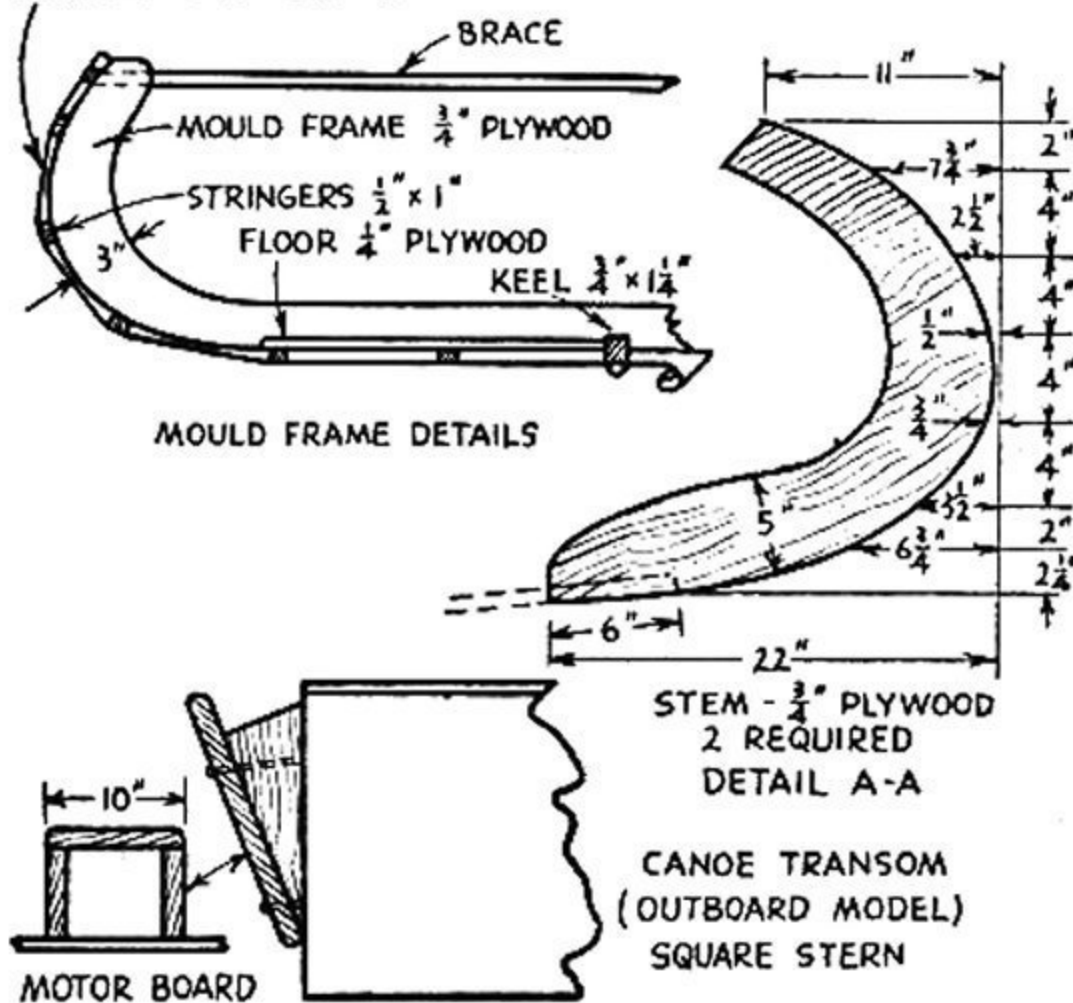

With hull removed from the form, saw braces to shape to fit each mold frame, slot the ends and fasten to the molds with screws. Breast hooks—which are simply pieces of 3/4" plywood—are secured to the sheer forward. Then 1/8" mahogany plywood is attached to cover stem and breast hook, being tacked in place.

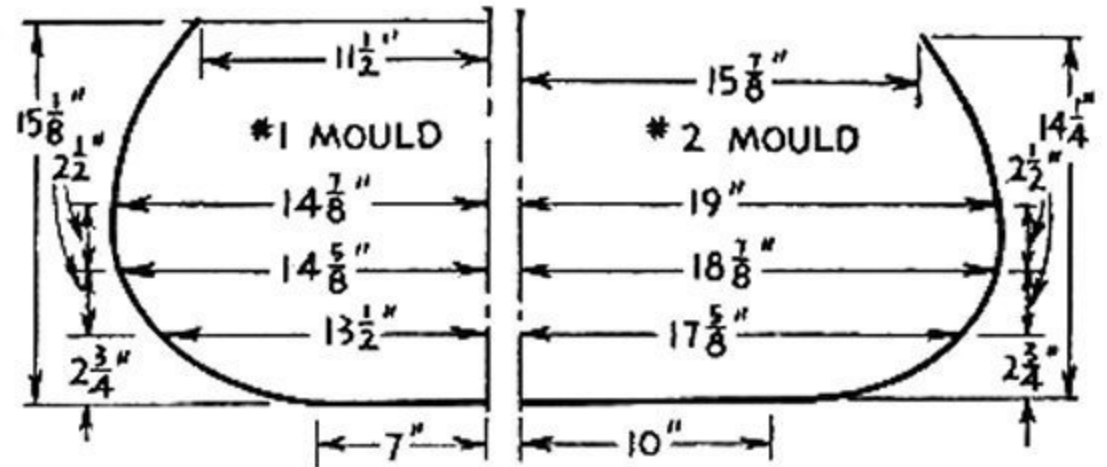

JOINT IN SHEER STRINGER FOR FILLERS

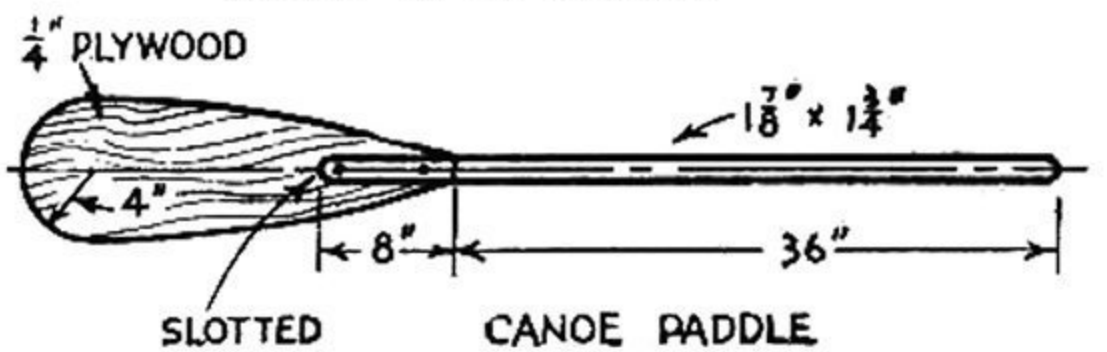
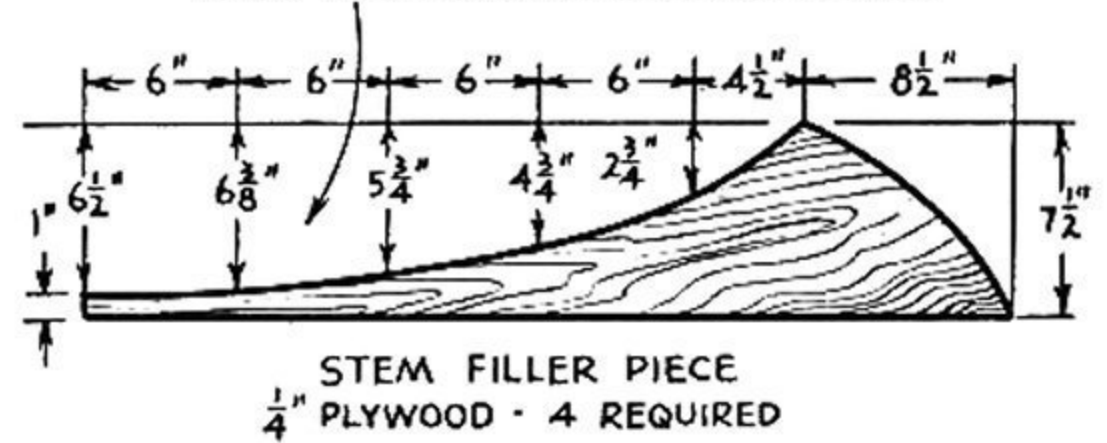

Moldings 1/4" x 3/4" are now fastened in place along the sheer with 3/4" No. 8 flat head screws spaced about eight inches apart. To protect the bottom from wear, an outer keel, 1/2" x 3/4", should be fastened in place with screws.

Flooring for the canoe consists of 1/4" plywood fastened to keel and stringers and shaped to fit snugly along the stringers.